

MPC-1000TM

Fire Alarm System Control Unit

Owner's Manual

12100-120

P/N 447051

Issue I Rev. C

4/2000



Faraday, LLC / 805 South Maumee Street / Tecumseh, Michigan 49286

Phone 517-423-2111

Fax 517-423-2320

Copyright © 1999, 2000, Faraday, LLC, All Rights Reserved

Table of Contents

I. INTRODUCTION.....	I-1
CONTROL UNIT LIMITATIONS.....	I-1
INSTALLATION AND WARRANTY INFORMATION.....	I-2
<i>Installer Information:</i>	I-2
<i>Original Purchaser Information:</i>	I-2
PREFACE.....	I-3
II. DESCRIPTIONS	II-1
SYSTEM DESCRIPTION.....	II-1
HARDWARE CONFIGURATION	II-1
MINIMUM CONTROL UNIT CONFIGURATION.....	II-2
<i>Power Supply</i>	II-2
<i>Status Relays</i>	II-2
<i>RS485 Communications Circuit</i>	II-2
<i>Notification Appliance Circuits</i>	II-2
<i>Addressable Device Circuit</i>	II-2
OPTIONAL CONTROL UNIT CONFIGURATION.....	II-2
<i>RS232 Communication Board</i>	II-2
<i>DACT Board</i>	II-2
BATTERY SETS.....	II-2
AUXILIARY MODULES.....	II-3
<i>Remote LCD Annunciator</i>	II-3
<i>Serial Relay Unit and Serial Relay Extender</i>	II-3
<i>Serial Annunciator Unit and Serial Annunciator Extender</i>	II-3
ADDRESSABLE DEVICES	II-3
<i>Addressable/Analog Sensors</i>	II-3
<i>Other Addressable Devices</i>	II-4
PROCESSOR CONTROLLED OUTPUT ZONES	II-4
<i>Output Sounding Patterns</i>	II-4
<i>Control of Audible Silencing</i>	II-4
<i>Audible Silence Inhibit</i>	II-4
EVENT HISTORY.....	II-5
GENERAL DESIGN FEATURES	II-6
<i>Environmental</i>	II-6
<i>Power Limiting</i>	II-6
<i>Ground Fault Detection</i>	II-6
<i>Transient Protection</i>	II-6
<i>Security Functions</i>	II-6
REGULATORY STANDARDS	II-6
<i>Federal Communications Commission</i>	II-6
<i>Underwriters Laboratories</i>	II-6
GENERAL SPECIFICATIONS.....	II-7
<i>Environmental</i>	II-7
<i>Primary Supply</i>	II-7
<i>Secondary and Trouble Power Supply</i>	II-7
<i>Auxiliary Power Outputs</i>	II-7
<i>Status Relays</i>	II-7
<i>Notification Appliance Circuits</i>	II-7
<i>RS485 Communications Circuit</i>	II-8
<i>Addressable Device Circuit</i>	II-8

RS232 Output (Optional RS232 Board P/N 12103).....	II-8
DACT Circuit (Optional DACT Board P/N 12105).....	II-8
III. CONTROL UNIT OPERATION.....	III-1
OPERATION INSTRUCTIONS	III-1
A. Standby Condition.....	III-1
B. Alarm Condition	III-1
C. Trouble Condition.....	III-2
D. Supervisory Condition	III-2
E. Maintenance.....	III-2
ADDITIONAL OPERATING PROCEDURES.....	III-3
A. Lamp Test.....	III-3
B. Drill.....	III-3
C. Recall.....	III-3
D. Pre-Alarm.....	III-3
E. General Alarm.....	III-3
F. Tornado.....	III-3
G. History	III-4
12100 OPERATING INSTRUCTIONS	III-5
12506 OPERATING INSTRUCTIONS	III-6
IV. CONTROL UNIT INSTALLATION	IV-1
PARTS SUPPLIED.....	IV-1
CAUTIONS	IV-1
CONTROL UNIT LOCATION.....	IV-1
ENCLOSURE MOUNTING.....	IV-1
A. Surface Mounting Instructions.....	IV-2
B. Semi-Flush Mounting Instructions.....	IV-3
C. Knock-Outs.....	IV-4
D. Main Board Installation.....	IV-4
E. Transformer Mounting	IV-4
F. Front Plate Assembly.....	IV-5
G. Front Plate Mounting.....	IV-5
H. Door Assembly.....	IV-6
I. AC Supply Connection.....	IV-6
J. Battery Installation.....	IV-6
K. Powering the Control Unit.....	IV-7
L. Checking Supervised Circuits.....	IV-7
M. Optional Modules.....	IV-7
N. System Wiring.....	IV-7
O. Check System Operation.....	IV-7
V. SYSTEM WIRING	V-1
CONTROL UNIT WIRING OVERVIEW	V-1
WIRING SEPARATION.....	V-2
PRIMARY AND SECONDARY POWER WIRING.....	V-2
STATUS RELAYS AND AUXILIARY POWER OUTPUTS WIRING	V-3
System Power Requirement Calculations	V-3
Auxiliary Power Supply.....	V-3
Battery Size Calculations.....	V-3
NAC WIRING.....	V-4
RS485 COMMUNICATIONS CIRCUIT.....	V-5
Remote Device Power.....	V-5
Remote Device Data.....	V-5
ADDRESSABLE DEVICE CIRCUIT.....	V-6
Addressable Device Wiring Diagrams.....	V-6

<i>Addressable/Analog Sensors</i>	V-11
<i>Addressable Modules</i>	V-17
VI. PROGRAMMING THE CONTROL UNIT	VI-1
MAIN BOARD JUMPER	VI-1
KEYPAD PROGRAMMING	VI-1
PROGRAMMING SECURITY	VI-1
VII. MAINTENANCE	VII-1
GENERAL	VII-1
QUICK TEST	VII-2
VIII. APPENDIX-A: REFERENCE DATA	VIII-1
WIRE SELECTION GUIDES	VIII-1
<i>Resistance of Solid Copper Wire</i>	VIII-1
<i>Notification Appliance Circuit Wire Selection Guide</i>	VIII-1
<i>Addressable Device Circuit Wire Selection Guide</i>	VIII-2
BATTERY SIZE CALCULATIONS	VIII-3
IX. APPENDIX-B: COMPATIBLE DEVICES	IX-1
COMPATIBLE DEVICES FOR ADDRESSABLE DEVICE CIRCUITS	IX-1
<i>Addressable Sensors</i>	IX-1
<i>Sensor Bases</i>	IX-1
<i>Accessory Modules</i>	IX-1
COMPATIBLE DEVICES FOR INITIATING CIRCUITS	IX-2
<i>Manual Stations</i>	IX-2
<i>Waterflow Switches</i>	IX-2
<i>Supervisory Switches</i>	IX-3
<i>Contact Type Heat Detectors</i>	IX-3
<i>UL Compatible Four-Wire (Separately Powered) Smoke Detectors</i>	IX-4
DEVICES FOR NOTIFICATION APPLIANCE CIRCUITS	IX-5
<i>Compatible Notification Appliances</i>	IX-5
COMPATIBLE ACCESSORY DEVICES	IX-12
DEVICES FOR AUXILIARY POWER OUTPUTS	IX-12
<i>Door Holders</i>	IX-12
<i>Relays</i>	IX-12
X. APPENDIX-C: TROUBLESHOOTING	X-1
DEFINITIONS FOR EVENT HISTORY ENTRIES	X-1
A. <i>General</i>	X-1
B. <i>System Troubles</i>	X-2
C. <i>System Events</i>	X-3
XI. APPENDIX-D: INSTALLATION INSTRUCTIONS	XI-1
12103 <i>RS232 Board - 447054</i>	XI-3
12105 <i>Serial Digital Communicator - 447063</i>	XI-5
12408 <i>Auxiliary Power Supply - 446066</i>	XI-9
12506 <i>Remote LCD Annunciator - 446983</i>	XI-19
12507/12508 <i>Serial Relay Unit/Serial Relay Extender - 447073</i>	XI-21
12509/12510 <i>Serial Annunciator Unit/Serial Annunciator Extender - 447074</i>	XI-23
401403 <i>Fire Alarm Accessory Enclosure - 447138</i>	XI-25
XII. APPENDIX-E: GLOSSARY	XII-1

This page is intentionally blank.

I. INTRODUCTION

CONTROL UNIT LIMITATIONS

This control unit may not show an alarm condition without compatible initiating devices (smoke detectors, etc.) and notification devices (horn, lights, etc.) connected to it. Electrical ratings of the initiation and notification appliances must be compatible with the electrical ratings of the control unit and must be properly interconnected. The wiring used for interconnection must be large enough to carry the total current for all appliances without excessive voltage drop.

The control unit must be connected to a dedicated primary electrical source that has a high degree of reliability and adequate capacity for this control unit. The only means of disconnecting this power source shall be available only to authorized personnel and clearly marked "Fire Alarm Circuit Control".

The control unit must also have connected to it a battery set (24v) that has enough capacity to properly operate the system for 24 or 60 (depending on system type) hours standby and 5 minutes alarm per NFPA 72 (chapter 1). These batteries do lose capacity with age. Batteries must be replaced when they fail to provide the control unit with the required standby and alarm power or after 4 years, whichever happens first. These batteries must be checked for performance at least two (2) times a year or more often if local requirements dictate.

Fire alarm control units cannot last forever. Even though this control unit was made to last for the expected life of the fire alarm system, any part could fail at any time. Therefore a regular test program should be followed and documented to make sure that each part of the system is tested as in Chapter 7 of NFPA 72 or more often if dictated by local code requirements. Malfunctioning units must be replaced or repaired immediately by factory authorized service personnel.

NOTE: This control unit is designed to show an alarm condition when the initiating devices connected to it detect specific conditions. These conditions may or may not represent a life-threatening condition. Also, evacuation of a building or area unnecessarily may subject individuals to an unnecessary hazard. Therefore, it is most important that the building owner, manager, or representative promulgate, distribute, and/or post instructions describing steps to be taken when the fire alarm control unit signals an alarm condition. These instructions should be developed in cooperation and conformance with representatives of the local authority having jurisdiction.

As a backup or precautionary measure, it is strongly suggested that one of these steps should be to notify the local fire department of an abnormal condition even where the DACT option (or similar device) is included in the system.

INSTALLATION AND WARRANTY INFORMATION

Warranty Information: Faraday, LLC (the Manufacturer) provides a limited warranty to the original purchaser of this product. The original purchaser is the party to whom the manufacturer issued its sales order, generally the manufacturer's distribution. In order to preserve this warranty, it is important that only persons who have been properly trained and authorized by the manufacturer service the product.

Other parties involved in the installation of this product may have also provided a warranty, which may be different from that of the manufacturer. The manufacturer will only be responsible to the original purchaser and only for the manufacturer's own warranty. For further information regarding the manufacturer's warranty, contact the original purchaser.

OWNER'S MANUAL: The owner's manual does not purport to cover all the details or variations in the equipment described, nor does it provide for every possible contingency to be met in connection with installation, operation and maintenance. All specifications subject to change without notice. Should further information be desired or should particular problems arise which are not covered sufficiently, the matter should be referred to the installer or original purchaser listed below.

Installer Information:

Company:
Installer:
Phone:
Address:
City:
State:
Zip:
Date installed:
Installer's signature:

Original Purchaser Information:

Company:
Phone:
Address:
City:
State:
Zip:
Purchaser's purchase order number:
Date purchased:
Faraday sales order acknowledgment number:
Original purchaser's signature:

PREFACE

Along with the use of this instruction manual, the appropriate following standards and the manufacturer's instructions for initiating and notification devices should be used to install and maintain a functioning fire alarm signaling system.

NFPA 70 National Electrical Code

NFPA 72 National Fire Alarm Code

NFPA 101 Life Safety Code

For other standards that may apply contact the authority having jurisdiction.

For NFPA publications, contact:

National Fire Protection Association
Batterymarch Park
Quincy, Massachusetts 02269

This page is intentionally blank.

II. DESCRIPTIONS

SYSTEM DESCRIPTION

The 12100 is an advanced modular fire alarm control unit. It features addressable/analog detection, programming, and memory capability. Its base configuration includes one addressable device circuit, with four conventional notification appliance circuits.

The basic 12100 control unit mounts in a 14-3/8" x 14-3/8" back-box with overall cover size of 14-3/4" x 14-21/32". Operating controls and indicators are mounted on the plate with a polycarbonate decal for identification. An 80-character LCD display provides specific indications for addressable devices while LEDs indicate general panel status.

Semi-flush mounting kits are available for the enclosure.

HARDWARE CONFIGURATION

The main board mounts in the rear of the enclosure. The power supply is physically contiguous with the main board. The 12100 main board provides the interface for external analog system connections, for the addressable device circuit, four notification appliance circuits, remote signaling and indicating interfaces, and the electronics of the main system power supply. Optional boards mount on the main board.

The display board mounts on the front plate, allowing it to carry the controls and displays which must be accessible.

All normal operation is controlled from the front of the control unit via push-button switches. Displays are provided by an 80-character, alphanumeric, backlit LCD display and by discrete LED indicators for major control unit functions.

The 80-character LCD display is used to display event data, including alarms and troubles, identification of zone or device, and presentation of history. The display is controlled by a set of four push-button switches commanding the control processor. A back light is included in the display to assure visibility in low light, but to conserve power, it is only activated during a reported event or on operation of a display control switch.

Individual LEDs on the panel are provided to indicate SYSTEM ALARM, PREALARM, SUPERVISORY, ALARM SILENCED, SYSTEM TROUBLE and AC POWER ON. Direct push-button controls are provided for ALARM SILENCE, TROUBLE SILENCE/ACKNOWLEDGE, MENU and SYSTEM RESET.

MINIMUM CONTROL UNIT CONFIGURATION

Power Supply

A 3A, 24V nominal power supply provides all operating power to the control unit for both standby and alarm conditions. Sufficient battery charging capability is available to charge sealed lead-acid batteries within code requirements for 60 hour quiescent plus 5 minutes alarm. The cabinet will hold batteries only up to 7 AH. The back-up battery is 24V, maintained by floating on the power supply. The power supply is physically contiguous with the main board.

Status Relays

Three dry relay contacts are provided. These contacts are dedicated to alarm, trouble and supervisory indications. The relay contacts are form C and are rated 1A @ 28VDC resistive.

RS485 Communications Circuit

The 12100 control unit has a RS485 Communications Circuit that will drive up to 16 remote LCD annunciators and 8 Serial Relay Units and Serial Annunciator Units on the RS485 communication line.

Notification Appliance Circuits

The base 12100 control unit has four independent notification appliance circuits (NACs). Each circuit can be selected to give continuous output or one of eight sounding patterns available in the control unit. There is also a system coder capable of zone coded operation. All of the NACs are power limited and can be wired for Class A (Style Z) or Class B (Style Y) operation.

Addressable Device Circuit

The 12100 main board has an addressable device circuit supporting one addressable device communications loop. This circuit drives System Sensor devices, with up to 99 addressable sensors and 99 addressable modules.

OPTIONAL CONTROL UNIT CONFIGURATION

A maximum control unit configuration can include all of the minimum configuration items plus additions as noted below. Details of these accessories are given in Appendix D.

RS232 Communication Board

The Faraday 12103 RS232 communication board will allow event data to a serial printer or terminal.

DACT Board

The Faraday 12105 Digital Alarm Communication Transmitter board will send control unit status data to a remote receiving station.

BATTERY SETS

The 12100 control unit is designed to use only sealed lead-acid or equivalent batteries for back-up power. Attaching a close-coupled battery box, if required, may use battery sets beyond the physical capacity of the enclosure (7 AH).

AUXILIARY MODULES

Remote LCD Annunciator

The Faraday 12506 remote LCD annunciator consists of a backlit 80 character LCD alphanumeric display, 4 menu buttons, 4 dedicated buttons for operator interaction, 6 LED indicators, and a security key-switch. The display and controls on the annunciator are the same as those on the front of the control unit, including a key-switch for security. The back light operates only when the data are being accessed, to conserve power.

Up to sixteen annunciators may be addressed by the communications circuit, but some may require 12408 auxiliary power supplies, depending on the total accessory power loading.

Serial Relay Unit and Serial Relay Extender

The Faraday 12507 includes a processor board and a relay board. The processor board receives commands from the control unit for activating the relays and transmits supervision and control functions to the control unit. The processor board can control up to 3 relay boards. Each relay board provides 8 relays with form C contacts. The control unit can address up to 8 Serial Relay Units and/or Serial Annunciator Units. 12408 auxiliary power supplies will be required to power units beyond the control unit capability.

Serial Annunciator Unit and Serial Annunciator Extender

The Faraday 12509 includes a processor board and a annunciator driver board. The processor board receives commands from the control unit for activating the outputs and transmits supervision and control functions to the control unit. The processor board can control up to 4 annunciator driver boards. Each driver board provides 16 supervised outputs for LEDs or incandescent lamps. The control unit can address up to 8 Serial Relay Units and/or Serial Annunciator Units. 12408 auxiliary power supplies will be required to power units beyond the control unit capability.

ADDRESSABLE DEVICES

Addressable/Analog Sensors

Since an analog fire sensor is essentially a transducer rather than a warning device, all of the operating controls are included in the processor program. This allows considerably increased versatility with only one significant limitation - that since the incoming signal does not indicate a safe or alarm condition, degrade mode operation on processor failure does not apply.

Variable Thresholds

The obscuration level for alarm can be adjusted from the control unit on a permanent or time-variable basis. This facility also means that the 12100 control unit can display information on individual points for maintenance or service. These displays include:

- Status
- Current % obscuration for smoke sensors

Operator Alerts

The 12100 control unit can trigger an alarm or trouble automatically on the occurrence of a number of conditions of the sensor devices. These include:

- Maintenance alert
- Pre-alarm alert
- No response
- Incorrect response

Other Addressable Devices

Heat Sensors

Compatible heat sensing addressable devices may be intermixed on the circuit for locations where heat sensing may be the most effective detection mode.

Addressable Modules (Monitor and Control)

In addition to sensors, the circuit can communicate with addressable modules, allowing initiation devices or notification appliances with local power sources, and supervising the power sources.

Manual Stations

Addressable single and dual-stage manual stations may be intermixed on the circuit with proper response programmed into the control unit. For fastest response, manual stations should be connected so that their address is 1-9.

PROCESSOR CONTROLLED OUTPUT ZONES

While the notification appliance circuits are essentially hardware circuits, the fact that the outputs are commanded and controlled by the processor does provide more versatility than in a total hardware system. All functional selections are included in the control unit programming process.

Output Sounding Patterns

The notification appliance circuits are operable in different sounding patterns. Any circuit is selectable to any of eight software-generated patterns or continuous sounding. For convenience, three of the patterns are preprogrammed for March Time, Temporal, and Californian patterns.

Control of Audible Silencing

It is possible to select an "auto-silence" mode, adjustable from 0 to 255 minutes. Each notification appliance circuit programmed for alarm silence sequence, will be silenced upon time-out of the auto-silence timer. The alarm silenced LED will flash, indicating the auto-silence time-out.

Audible Silence Inhibit

In addition to designation of waterflow zones, the entire control unit may be programmed to inhibit audible silence for 0, 1, 3, or 6 minutes from the last alarm. System reset may also be inhibited.

EVENT HISTORY

The control unit includes a non-volatile memory recording up to 2000 system events. Identified alarm, trouble, supervisory trouble, and other significant events will be recorded along with the date and time of occurrence, and can be inspected by operating front panel push buttons.

Events recorded in the history are:

- Alarm, Trouble, or Supervisory conditions.
- Drill, Tornado, Recall and General Evacuation.
- Activation of NACs or modules used for sounders or strobes.
- Unit used for command functions. (Silence, acknowledge, reset, etc.)
- PAS_INHIBIT switch activation.
- Alarm silence (manual and automatic).
- System reset.
- Power up.
- Entry to Programmer Mode.
- Secondary configuration edited.
- Validity check on backup configuration. (Errors detected or no errors detected)
- Running of comparison function. (Same or different)
- Replacement of primary configuration.
- Execution of Auto-program.
- Exit from Programmer Mode.
- System time or date change.
- Input point disable/enable.
- Start and stop of walk test.
- Expiration of Walk Test Timer.
- Expiration of re-ring timer.
- Alarm/trouble/supervisory Acknowledgment.
- Trouble/supervisory restored to normal.
- Alarm verification counter rollover.
- Pre-alarm activation.
- Pre-alarm acknowledgment/restore.
- Alarm of zone with no outputs.
- Activation of points defined for logging.
- Sensor maintenance alerts

GENERAL DESIGN FEATURES

Environmental

All hardware is suitable for use in an interior or protected location.

Power Limiting

The AC power and battery wiring are not power limited. All other circuits leaving the control unit are power limited, provided the proper installation rules are maintained.

Ground Fault Detection

The control unit provides ground fault detection and a ground fault will trigger the common fault buzzer and system trouble LED.

Transient Protection

Transient protection devices are provided where needed to meet the requirements of UL864.

Security Functions

Processor control and addressing allow inclusion of several functions to assure security of the system.

Multi-level password protection of programming functions prevents unauthorized configuration changes.

Device type supervision: If the type reported by an addressable sensor or module, does not agree with the configuration, the system reports a trouble.

Device address supervision: The system checks that all configured devices on the addressable device circuit and the RS485 circuit responds to an address poll. If a configured device is missing, the system reports a trouble. The system also polls unused addresses periodically. If a device responds to such a poll of a non-configured device, the system reports a trouble. Two devices addressed the same also cause a trouble to be reported.

REGULATORY STANDARDS

The 12100 control unit meets the requirements of industry and government regulatory agencies as noted.

Federal Communications Commission

The 12105 also meets the requirements of the Code of Federal Regulations (CFR 47), Part 68, for connection of equipment to the public switched telephone network.

Underwriters Laboratories

The 12100 Fire Alarm control unit is listed under UL Standard 864 for compliance to NFPA Standard 72 for fire service

GENERAL SPECIFICATIONS

Operating specifications for the 12100 are as follows:

Environmental

- Operating temperature
32 - 120°F (0 - 49°C)
- Relative humidity
Up to 85% @ 86°F (30°C)

Primary Supply

- Primary Input Voltage: 120 VAC (60 Hz) nominal (12100-120)
- Maximum primary input current: 1.3A at 120 VAC

Secondary and Trouble Power Supply

- 24 volt lead-acid battery set:
- Maximum Charge Voltage: 27.8 VDC
- Maximum Charge Current: 1.0 A
- Maximum Input Current: 3.5A
- Battery capacity: 7-38 A.H. (over 7 A.H. requires separate enclosure)

Auxiliary Power Outputs

- Current:
0.5 amp maximum available for auxiliary power outputs, RS485 circuit and option boards
0.4 amp maximum per power output
- Non-Resettable Power Outputs
Power limited
Voltage: 24 VDC nominal
Ripple: 1.5 VAC maximum
- Resettable Power Output
Power limited
Voltage: 24 VDC nominal
Ripple: 1.5 VAC maximum

Status Relays

Includes alarm, supervisory and trouble.

- Contact Rating:
1 A, 28 VDC maximum, resistive
- Form "C" Contact

Notification Appliance Circuits

- Four Class A, Style Z/Class B, Style Y circuits
- Power limited
- Supervised
- Maximum Standby Current: 3.4mA
- Alarm Voltage: 24 VDC nominal
- Maximum Alarm Current: 1.5 A
- Maximum Ripple: 16 VAC
- Maximum Loop Drop Voltage: 1.0 VDC

RS485 Communications Circuit

- Power limited
- Supervised
- Voltage: 24 VDC nominal
- Current:
 - 0.5 amp maximum available for auxiliary power outputs, RS485 circuit and option boards
 - 0.4 amp maximum for RS485 circuit
- Maximum wire loop resistance: 25 ohms/line
- Communications: RS485

Addressable Device Circuit

- Power limited
- Supervised
- Voltage: 24 VDC nominal
- Maximum Current (shorted): 0.25A
- Maximum wire loop resistance: 20 ohms/line
- Communications: System Sensor
- 99 sensors (smoke, heat) max.
- 99 monitor and control modules max.

RS232 Output (Optional RS232 Board P/N 12103)

Power limited
Not supervised
Voltage Range: -15 VDC to +15 VDC
Maximum Current (shorted): 0.050A
Baud Rate: 4800
Maximum wire loop resistance: 25 ohms

DACT Circuit (Optional DACT Board P/N 12105)

Power limited
Supervised for short or open circuit
Maximum Voltage: 60 VDC
Maximum Current (shorted): 0.100 A

III. CONTROL UNIT OPERATION

OPERATION INSTRUCTIONS

A. Standby Condition

In normal standby operation, the green AC POWER ON LED should be illuminated and no other indicator operating. The display will show the system name, "System Normal" announcement and the current date, day, and time.

B. Alarm Condition

1) Normal Alarms

- a) In case of alarm, the system alarm LED will operate in a flashing mode and the buzzer will sound. Local audible and visual signals and remote alarm signals will operate, and the LCD panel display will indicate the zone or point initiating the alarm.
- b) On receipt of an alarm, proceed in accordance with the established emergency plan. Assure that all personnel are accounted for, and notify the Fire Department.
- c) To silence the audible after evacuation, where permitted by the codes and control unit programming, press ALARM SILENCE. The alarm audible will be silenced, the alarm silence LED will be illuminated and a system trouble indicated. Operating the ACKNOWLEDGE button will silence the local buzzer and change the LED alarm indicator from flashing to steady.

2) Waterflow Alarms

Alarms detected on zones designated "waterflow" indicate sprinkler operation and the audible alarms cannot be silenced in this condition. Operation of alarm silence will produce no effect.

3) Positive Alarm Sequence (PAS)

- a) Activation of a point programmed for PAS, including two-stage manual stations, activates the Alarm LED, display and buzzer (pulsing), but delays all other outputs (system and user) for 15 seconds.
- b) Operation of the ACKNOWLEDGE button within 15 seconds will add 165 seconds to the timer value, to make the total delay 180 seconds.
- c) If an ALARM SILENCE button is pressed or the sensor returns to a normal reading before the extended PAS delay time, the alarm sequence is aborted.
- d) An alarm condition on a sensor programmed for direct alarm response (such as the key switch on a manual station) will over-ride the PAS timer and activate the outputs.

4) Pre-Signal

- a) A point activated by a PRE-SIGNAL alarm activates the alarm relay, alarm DACT, alarm LEDs and buzzers, and all user programmed outputs normally, but does not activate any NACs.
- b) Operation of the ALARM SILENCE button less than 180 seconds after initiation of the alarm prevents operation of the NACs.
- c) Failure to act within 180 seconds will result in activation of the NACs.
- d) Receipt of another pre-signal or standard alarm during the delay period immediately sounds the NACs.
- e) A SYSTEM RESET is required to return the zone and input point to normal, whether or not the NACs were activated.

NOTE: Do not reset the system until the alarm condition has been cleared. The LCD display on the will indicate the area in which the alarm was detected. The detector initiating the alarm will display a light. If more than one zone is in alarm, the last zone to be alarmed will be indicated on the display.

f) When the alarm condition has been corrected, return the system to standby operation by pressing the SYSTEM RESET button.

C. Trouble Condition

a) In case of a trouble condition, the system trouble LED and any programmed trouble LEDs will be flashing, the LCD display will identify the problem, and the buzzer will sound. Refer to the applicable section of the system manual to determine the probable cause of the trouble and the action to be taken.

b) When a trouble has been noted, the buzzer may be silenced by pressing the ACKNOWLEDGE button. The trouble LEDs will change to a continuous display. If the trouble has not been corrected when the trouble re-ring timer expires, the trouble display will revert to its original condition and the buzzer resound.

c) If the control unit is programmed for trouble acknowledge required, when the indicated trouble condition has been cleared, the system will revert to standby condition after the ACKNOWLEDGE button is pressed.

Note: Some trouble conditions require a system reset to restore the control unit.

D. Supervisory Condition

Supervisory troubles are indicated similar to regular system troubles except that when a supervisory trouble is cleared, the cleared condition continues to be indicated until it is acknowledged.

E. Maintenance

In order to insure continued safe and reliable operation of the fire alarm system, periodic inspection and testing should be performed in accordance with applicable NFPA 72 standards.

CAUTION: If the system has remote connections to the Fire Department or other monitor, be sure to disable the remote signals and/or notify the remote monitoring station before performing test operations.

For any required service, refer to the system manual or contact a factory authorized representative.

ADDITIONAL OPERATING PROCEDURES

In addition to the basic fire alarm instructions above, several features are included to facilitate maintenance and increase the versatility of the system. Following are procedures to call up these functions.

A. Lamp Test

To operate the lamp test, press the MENU button. The LCD display will change to a MENU screen. Press the button next to the "More" indication twice. Then press the button by the "Lamp Test" indication. All lamps on the unit being operated will then light. Operating the button next to "Esc" will then return the control unit to normal display. Note that the lamp test operates the indicators only on the unit being operated, and no record is reported to system history.

B. Drill

To activate a fire alarm drill, proceed as follows:

1. Press "MENU".
2. On the MENU display, select "Manual Activation".
3. At the next screen, select "DRILL".
4. Select "More" if recall signal is used, or:
5. Select "Esc" to return to normal menu and:
6. Operate ALARM SILENCE to terminate drill signal.

C. Recall

To signal recall after a drill, proceed as follows:

1. If step 4 of the Drill procedure was followed, proceed to step 5.
2. Press "MENU".
3. On the MENU display, select "Manual Activation".
4. At the next screen, select "More".
5. Select "RECALL".
6. Select "Esc" to return to normal menu.
7. Operate ALARM SILENCE to terminate drill signal.

D. Pre-Alarm

1. A pre-alarm condition is annunciated by Pre-alarm LEDs and buzzers on the control unit and RS485 LCD Annunciators and RS485 Remote Processors. The LEDs flash and buzzers are on steady until acknowledgment.
2. Acknowledging the Pre-alarm condition puts LEDs on steady and buzzers off.
3. If pre-alarm has been acknowledged and restores to normal, the condition clears. If the system proceeds into an alarm condition, the pre-alarm condition clears whether or not it has been acknowledged and is replaced by alarm.

E. General Alarm

To activate a general alarm, proceed as follows:

1. Press "MENU".
2. On the MENU display, select "Manual Activation".
3. At the next screen, select "GENERAL EVACUATION".
4. Select "Esc" to return to normal menu and:
5. Silence and reset the system as with any alarm.

F. Tornado

To activate a tornado alarm, proceed as follows:

1. Press "MENU".
2. On the MENU display, select "Manual Activation".
3. At the next screen, select "More".
4. Select "TORNADO".
5. Operate ALARM SILENCE to terminate tornado signal.
6. Select "Esc" to return to normal menu.

G. History

The last 2000 system events are time-tagged and recorded for review in the user level event history. This history is available to anyone with the user security key, but may be erased only at the maintenance security level.

1. Operation of history:
 - a) New events overwrite old when filled.
 - b) Printer (if used) records all events.
 - c) For more information see the event history section

2. Access to history:

To recall past events, proceed as follows:

- a) Press MENU button.
- b) Operate button identified as "More".
- c) Operate button identified as "View Events".
- d) Operate lower left button for next event display.
- e) Operate upper left button for previous event display.
- f) Operate upper right button to return to first menu.
- g) Operate "Esc" to return to normal display.

12100 OPERATING INSTRUCTIONS

Alarm Operation

In case of alarm, the *System Alarm* LED flashes, LCD will display alarm conditions and the panel buzzer sounds. Local audible and visual signals and remote alarm signals operate.

When an alarm occurs, proceed according to the established emergency plan. Assure that all personnel are accounted for, and notify the Fire Department to advise of the alarm and/or verify that an automatic signal has been received at the Fire Department.

Authorized Personnel Only

To silence the alarm:

To silence the notification appliances after evacuation, where permitted, press the **Alarm Silence** switch. The notification appliances and panel buzzer will be silenced, and LED indications will change from flashing to continuous. The *Alarm Silenced* LED will be lit.

Note: Do not reset the panel until the alarm has been cleared.

Warning: Alarm silence inhibit (if set) prevents the alarm from being silenced for a predetermined time.

To reset panel after alarm:

When the alarm condition is corrected, return the panel to normal standby operation by pressing the **System Reset** switch.

Trouble Operation

Trouble is indicated by:

System Trouble LED flashes
LCD will display trouble conditions
Panel buzzer sounds

To silence the trouble buzzer:

Press the **Trouble Silence** switch. The *Trouble Silenced* LED lights and the specific trouble LED(s) may change to continuous display. When the trouble condition has been cleared, you may need to reset the panel to restore to a normal standby condition.

Warning: Leaving the panel in a trouble condition may cause a fire alarm condition not to initiate a fire alarm sequence

Normal Standby Condition

The green *AC Power On* LED will be lit and no other indicators on.

For service, contact: _____
Telephone Number: _____

Frame these instructions and mount them near the control unit for operator reference.

12506 OPERATING INSTRUCTIONS

Alarm Operation

In case of alarm, the System *Alarm* LED flashes, LCD will display alarm conditions and the buzzer sounds. Local audible and visual signals and remote alarm signals operate.

When an alarm occurs, proceed according to the established emergency plan. Assure that all personnel are accounted for, and notify the Fire Department to advise of the alarm and/or verify that an automatic signal has been received at the Fire Department.

Authorized Personnel Only

To silence the alarm:

To silence the notification appliances after evacuation, where permitted, operate the **Button Enable** keyswitch and press the **Alarm Silence** switch. The notification appliances and buzzer will be silenced, and LED indications will change from flashing to continuous. The *Alarm Silenced* LED will be lit.

Note: Do not reset the panel until the alarm has been cleared.

Warning: Alarm silence inhibit (if set) prevents the alarm from being silenced for a predetermined time.

To reset panel after alarm:

When the alarm condition is corrected, return the panel to normal standby operation by using the **Button Enable** keyswitch and then pressing the **System Reset** switch.

Trouble Operation

Trouble is indicated by:

System *Trouble* LED flashes
LCD will display trouble conditions
Buzzer sounds

To silence the trouble buzzer:

Operate the **Button Enable** keyswitch and press the **Trouble Silence** switch. The System *Trouble* LED changes to continuous display. When the trouble condition has been cleared, you may need to reset the panel to restore to a normal standby condition.

Warning: Leaving the panel in a trouble condition may cause a fire alarm condition not to initiate a fire alarm sequence

Normal Standby Condition

The green *Power On* LED will be lit and no other indicators on.

For service, contact: _____
Telephone Number: _____

Frame these instructions and mount them near the annunciator for operator reference.

IV. CONTROL UNIT INSTALLATION

PARTS SUPPLIED

447039, 447040 or 447041	Back-box Assembly (red, white or black)	
413690, 413691 or 413692	Door Assembly (red, white or black)	
413535	Transformer Assembly (120VAC)	18965 #6-32 Keps Nuts (6)
413688	Front Plate Assembly	29529-11 #6-32 x 1/4" Screws (16)
413693	Main Board	942155 #8-32 Sems Screw, (4)
413694	Display Board	942667 24K Ohm 1/2W Resistor (4)
446054	Cable Assembly, 16 Pin	443269 Screwdriver
447071	Lexan Window	447051 Owner's Manual
447072	Overlay	447058 Operating Instructions
943966	Programming Keypad	942664 120 Ohm 1/2W Resistor (2)

The fire alarm control unit must be mounted in a properly accessible location as required by applicable codes. Any auxiliary battery box or other accessory not connected through a protective device or a circuit designed for remote connection must be within the same room and connected through electrical conduit. Installation is to be done only by qualified personnel who have thoroughly read and understood these instructions.

CAUTIONS

It is recommended that the printed circuit boards be removed for any procedure that may cause dust, metal shavings, grease or any such matter that may affect the circuit boards and/or parts. There may be several sources of power into the control unit. Each source must be disconnected prior to installing or removing modules, connecting or disconnecting wiring, and programming jumpers.

CONTROL UNIT LOCATION

The control unit should be located near an exit at ground level, where the normal ambient temperature is maintained within the control unit specification (See General Specifications in Section III). The unit should be in an area that is free of dust, vibration, moisture and condensation.

ENCLOSURE MOUNTING

Follow the appropriate instructions for surface or semi-flush mounting.

A. Surface Mounting Instructions

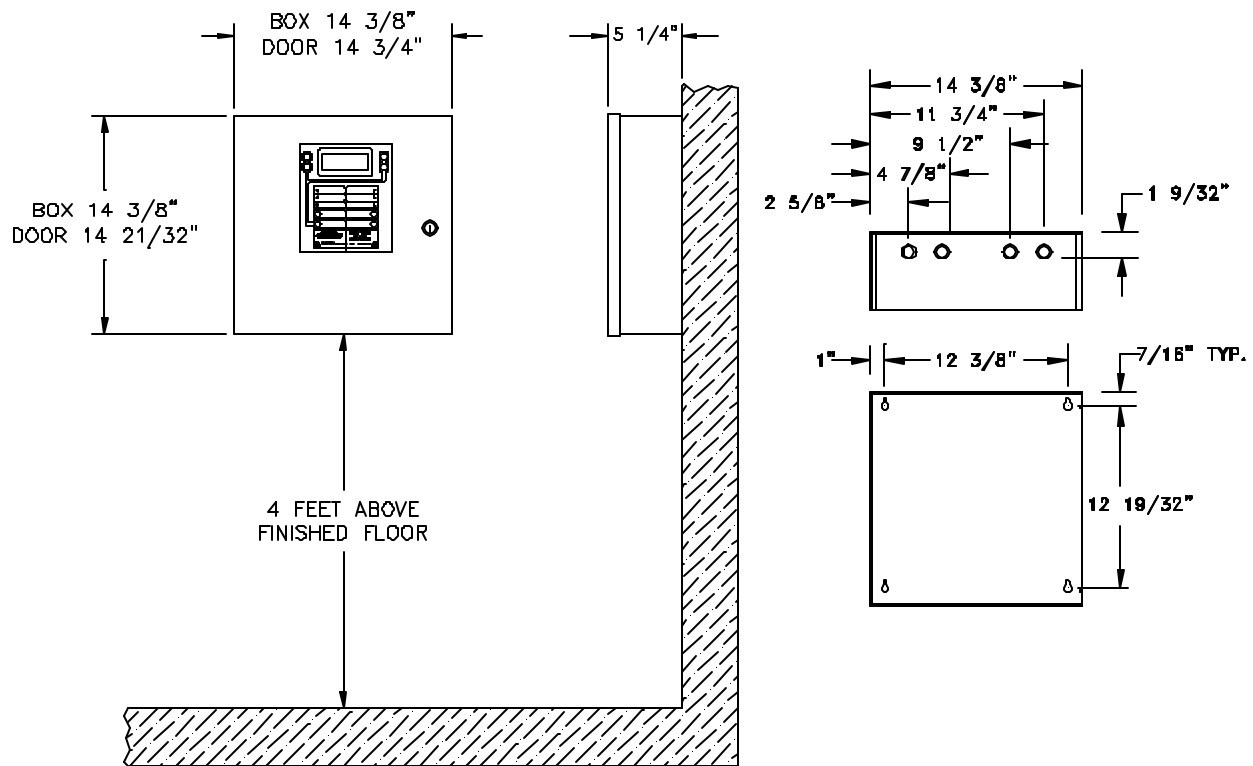

To mount the enclosure:

1. Mount the enclosure at a convenient height for viewing indicators and operating switches.
2. Use four #10 lag screws (not supplied) to secure the control unit to the wall. The screw type and length must support the control unit, options and battery set.

Note: You may need a different screw type, depending on the wall material.

3. The 12408 Auxiliary Power Supply or battery enclosure may be mounted immediately below the main enclosure, close nipple, allowing a minimum of 1 inch in between the enclosures for clearance between the doors. Keeping the wire run to the control unit short will keep the voltage drop to a minimum.

B. Semi-Flush Mounting Instructions

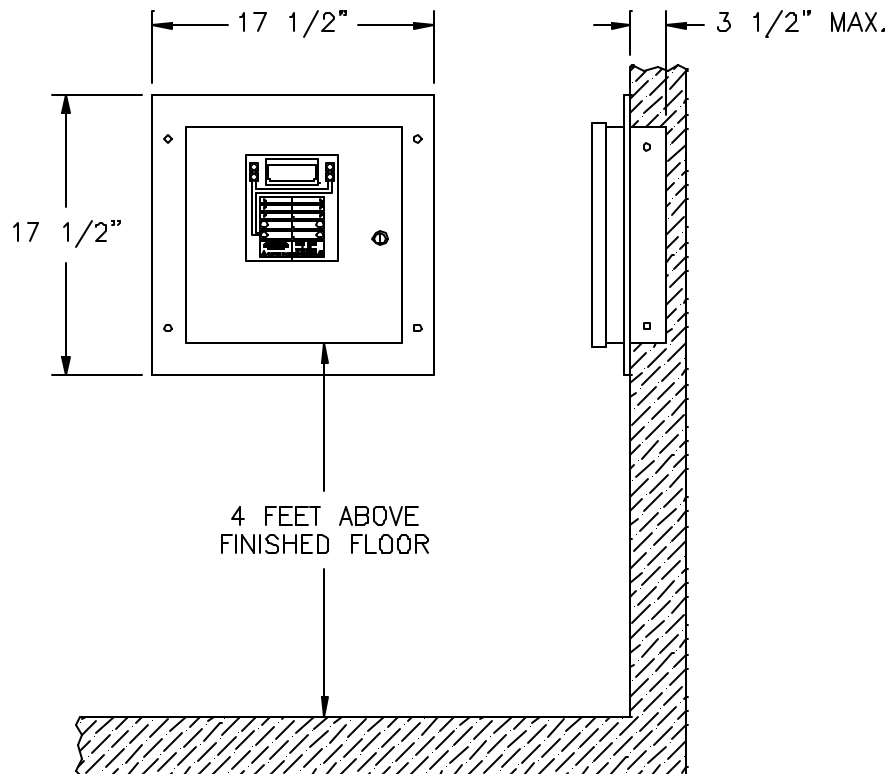

To mount the enclosure:

1. Mount the enclosure at a convenient height for viewing indicators, and operating switches.
2. Use four #10 lag screws (not supplied) to secure the control unit to the wall. The screw type and length must support the control unit, options and battery set.

Note: You may need a different screw type, depending on the wall material.

3. The back-box can be mounted up to 3 1/2 inches into the wall. Place the semi-flush trim around the back-box and affix to the wall with four #10 x 3/4 inch wood screws (provided with trim).

Note: You may need a different screw type, depending on the wall material.

4. The 12408 Auxiliary Power Supply or battery enclosure may be mounted immediately above or below the main enclosure, close nipple, allowing a minimum of 3 inches in between the enclosures for clearance between the semi-flush trims. Keeping the wire run to the control unit short will keep the voltage drop to a minimum.

C. Knock-Outs

1. Prepare the enclosure for electrical wiring, break out the appropriate conduit entry points. Note the wiring diagram requirements for non-power limited and power limited wiring separation.
2. Attach conduit (if required) and run wires as required. Label each field cable for future reference.

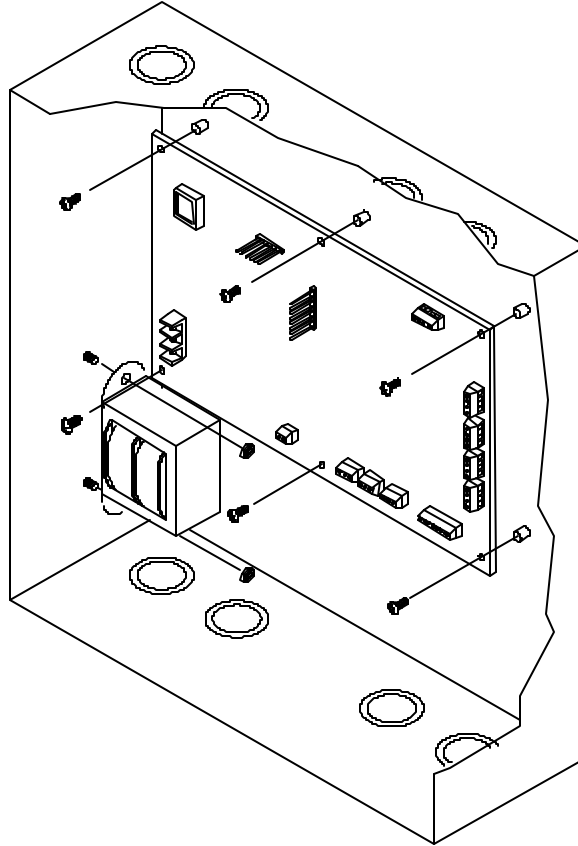

D. Main Board Installation

1. Secure the board to the back of enclosure using six of the provided #6-32 x 1/4 screws (P/N 29529-11).

E. Transformer Mounting

1. Place the transformer assembly (P/N 413535) over the studs on the left side of the enclosure. Mounting the transformer can be accomplished before mounting the enclosure if desired.
2. Tighten transformer-mounting nuts (P/N 18965).
2. Plug the transformer assembly into connector P5 on the Main Board.

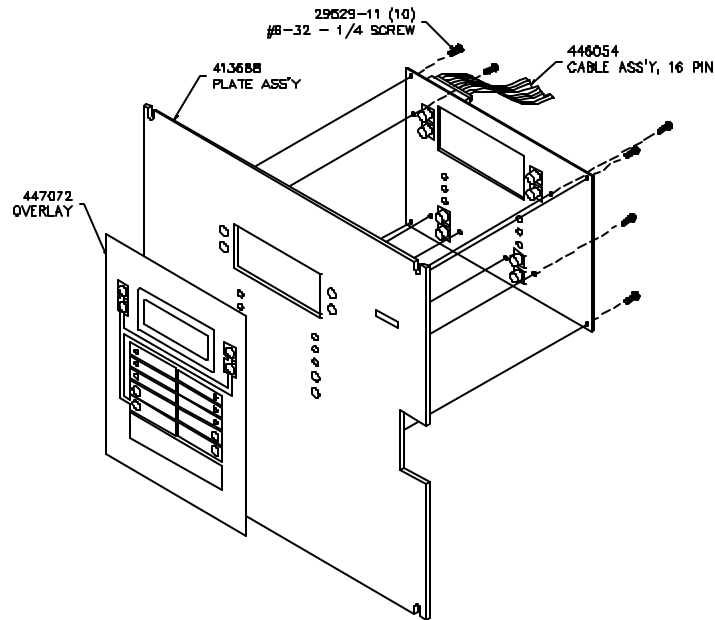

F. Front Plate Assembly

1. Secure Display Board (P/N 413694) to Plate Assembly using ten #6-32x1/4" screws (P/N29529-11).
2. Apply Overlay (P/N 447072) to Plate Assembly (P/N 413688)

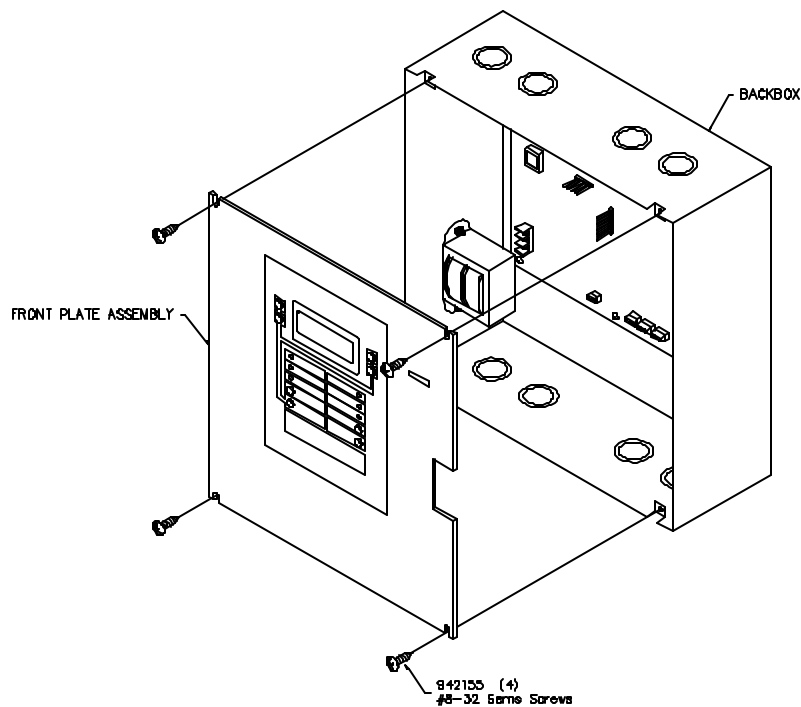

G. Front Plate Mounting

1. Plug the Cable Assembly (P/N 446054) into connector P4 of the Display Board and to connector P1 of the Main Board.
2. Secure the Front Plate Assembly to backbox using four #8-32 sems screws (P/N 942155).

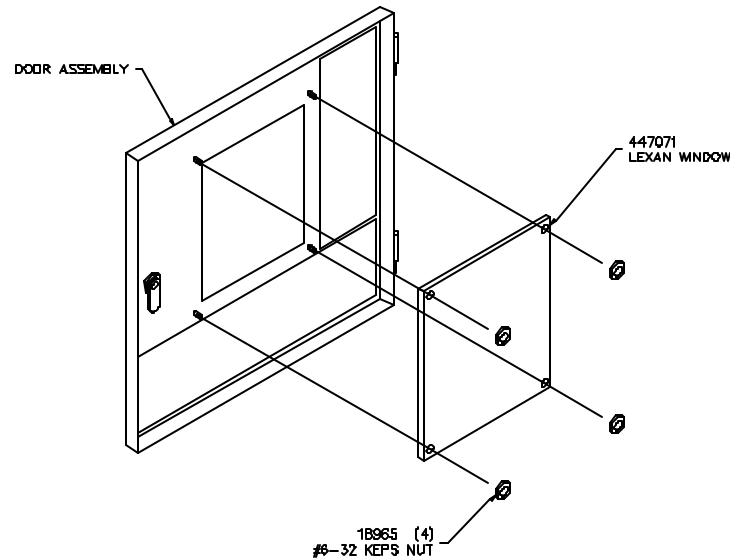

H. Door Assembly

1. Secure the Lexan window (P/N 447071) to door assembly using four #6-32 keps nuts (P/N 18965).
2. Place the Door Assembly onto hinges of the Back-box Assembly.

I. AC Supply Connection

Wire the AC supply to terminal block TB2 on the main board. The supply should originate from a separate, fused circuit. It should be provided with a breaker or other means of isolation.

Observe the wiring order -- the bottom terminal is ground and must be wired back to the electrical panel ground (earth) bonding point or another good ground acceptable to the authority having jurisdiction and the electrical inspector. The neutral wire must be taken back to the electrical panel neutral distribution bar and must not be grounded.

/!\ Dangerous voltages will be present on this terminal block and on other components surrounding it and the transformer when the AC supply is turned on. Do not touch.

J. Battery Installation

Warning: Improper battery connections or shorting battery terminals may damage the system and/or batteries and may cause personal injuries.

Place the batteries in the space provided in the bottom of the back-box. If larger than 7 AH battery set is required, a separate enclosure must be used. The Faraday 14050 may be used for battery sets 18 AH and smaller. The Faraday BE-1S may be used for battery sets 38 AH and smaller.

The control unit uses a 24V battery set. Connect the two 12V batteries (or four 6V batteries) in series with #12 AWG wire, minimum. Route the battery leads to the left of the enclosure and up to the battery termination block, TB5. The battery leads are not power-limited.

Observe polarity. Connect the B- terminal from the main board into the black or - terminal of the battery set and the B+ terminal from the main board into the red or + terminal of the battery set.

K. Powering the Control Unit

Apply AC power to the control unit AC POWER ON LED, SYSTEM TROUBLE LED, and the trouble buzzer should be on.

L. Checking Supervised Circuits

To check the supervised circuits of the control unit:

1. Place a 24K ohm resistor (color-coded: red, yellow, orange) across each set of NAC terminals.
2. Push SYSTEM RESET button.
3. The SYSTEM TROUBLE LED, and the trouble buzzer should be off.
4. Discard 24K ohm resistors after initial testing is complete

M. Optional Modules

Follow the installation instructions provided in Appendix D.

N. System Wiring

Before connecting the field wiring, check the wiring for opens, shorts, grounds and stray voltages.

Warning: Damage may result if a high voltage insulation tester is used on wiring while connected to the control unit.

Terminate the field wiring to the main board in accordance with the diagrams in Section V and the system design documents.

NOTE: All wiring must be in accordance with local codes and the National Electrical Code. Use only FPL, FPLR and/or FPLP as described in Article 760 of the National Electric Code.

O. Check System Operation

Check for proper operation of all the system functions. See Section II for Operation Instructions.

This page is intentionally blank.

V. SYSTEM WIRING

Basic system wiring and detector siting must be in accordance with NFPA 72 or other instructions from the appropriate local authority. Unit connections and limitations are as indicated on the wiring diagram included below.

Devices that may be satisfactorily used with the control unit are shown in the compatible device listing in Appendix B.

Wire reference data are included in Appendix A.

CONTROL UNIT WIRING OVERVIEW

The overall arrangement of boards in the control unit is shown in the following diagram.

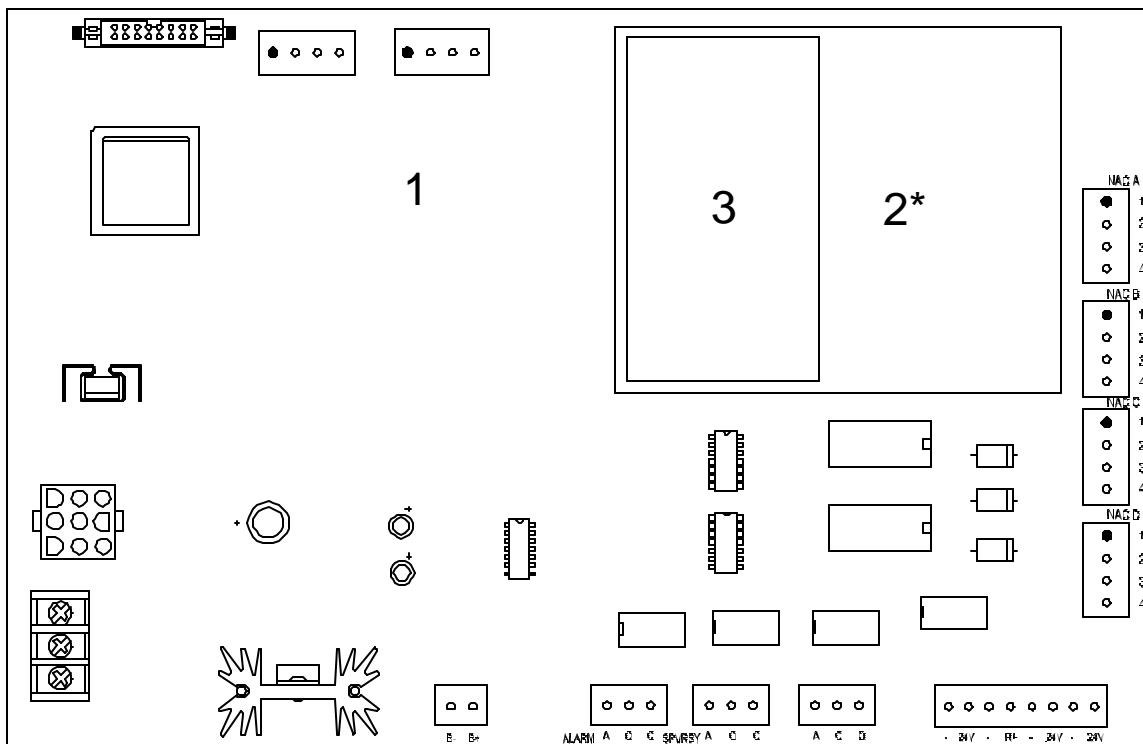

1. Main Board
 2. 12105 DACT Board
 3. 12103 RS-232 Interface Board
- * (Note: When using DACT, 12103 cannot be used)

WIRING SEPARATION

All high voltage and non-power limited wiring must be kept separate from power limited wiring. A 1/4" separation must be maintained, with high voltage and non-power limited wiring running in separate conduit openings from power limited wiring.

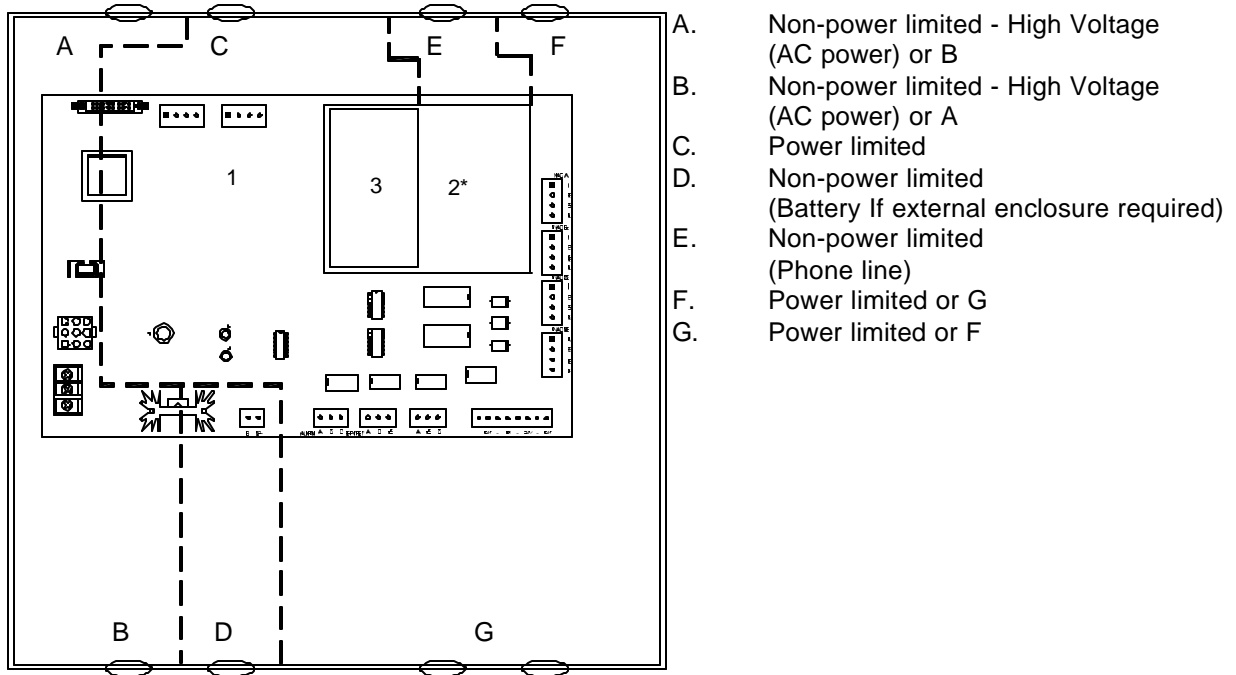

PRIMARY AND SECONDARY POWER WIRING

The AC main control board. Route all wiring

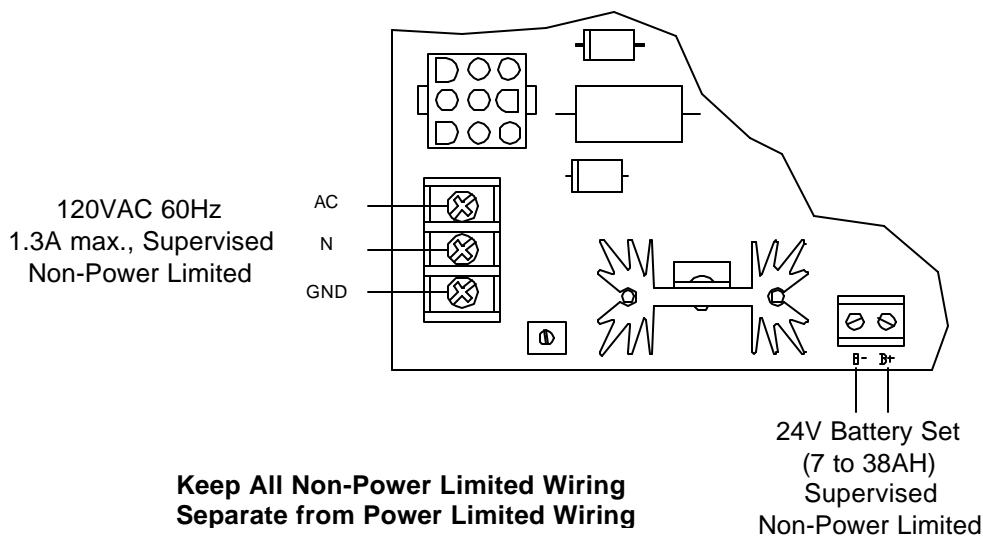

STATUS RELAYS AND AUXILIARY POWER OUTPUTS WIRING

The right lower edge of the main board provides for connection of contacts and auxiliary power connections.

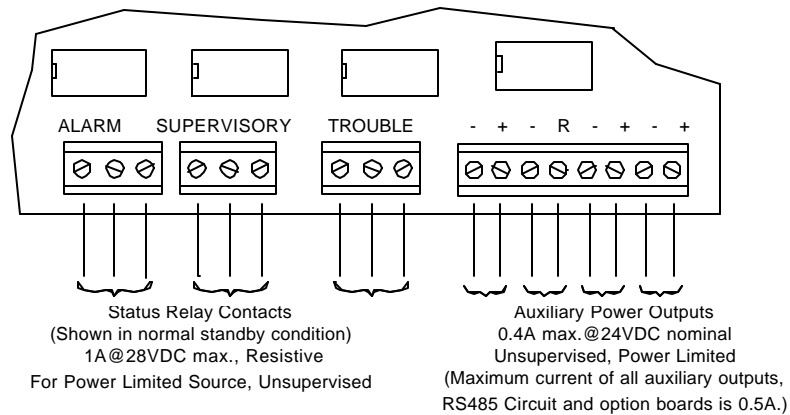

System Power Requirement Calculations

Device	Item Max.(Amps)	Total (Amps)
12100 Control Unit	0.200	0.200
Addressable Device Circuit Power	# of Devices X 0.0002 Amps	
Auxiliary Power Outputs *	Depends on devices installed	
12103 RS232 Communication Board	0.008	
12105 DACT Board	0.054	
12506 Remote LCD Annunciator *	0.030	
12507/12508 Serial Relay Unit *	0.030	
12509/12510 Serial Annunciator Unit *	0.030	
Total must not exceed 0.75 Amps		

Auxiliary Power Supply

* Connect a 12408 auxiliary supply when power requirement calculation indicates that an additional source is required. For further information, refer to the installation instructions in Appendix D

Battery Size Calculations

For calculation of battery size requirements see appendix A.

NAC WIRING

At the right hand side of the main board the terminal blocks are used for the connection of notification appliances. Four individual NACs marked A through D are provided and the polarity shown is when the NAC is activated.

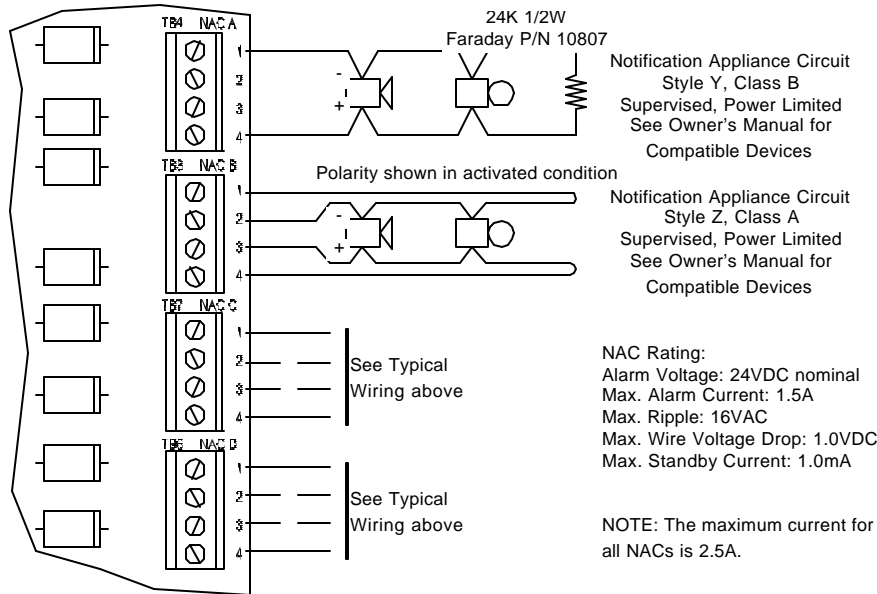

RS485 COMMUNICATIONS CIRCUIT

The RS485 communication circuit can address up to 16 standard annunciators and/or 8 remote processors to drive graphic annunciation or relay modules. Devices on the circuit may be connected up to 4000 feet from the control unit. At the top of the main board the terminal blocks are used for the connection of remote serial devices.

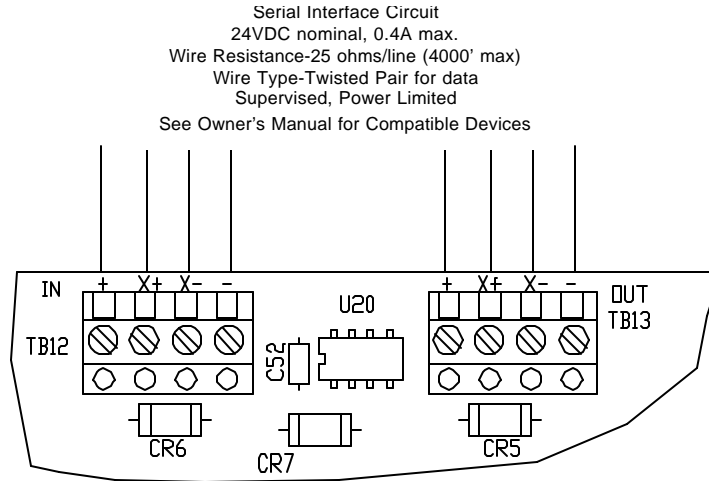

Remote Device Power

When connecting devices on the RS485 communications circuit, a limited amount of current is available from the control unit. If more current supply is required for the connected devices, auxiliary power must be provided to each insufficiently powered device. Each address on the circuit must be fully powered from either control unit or auxiliary power (*no combined source can be configured*).

Remote Device Data

When connecting devices on the RS485 communications circuit, the data wires must be daisy chained and with no T-taps to preserve the integrity of the data. Each end (two places) must be terminated with a 120 ohm termination resistor. The following diagrams show the proper wiring.

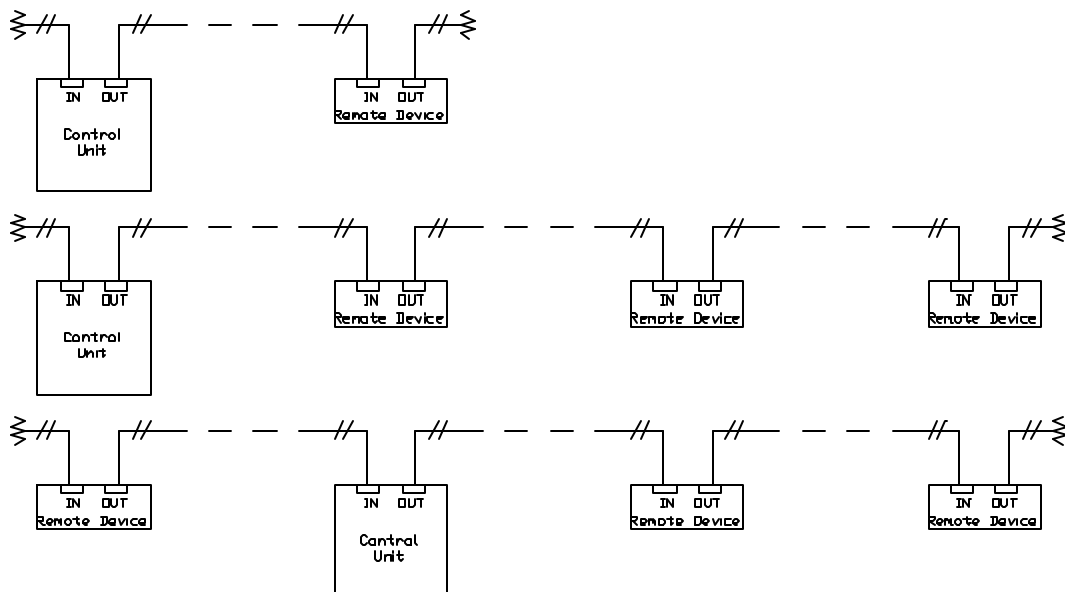

ADDRESSABLE DEVICE CIRCUIT

The basic configuration of the 12100 control unit includes one addressable device circuit. The circuit can include up to 99 sensors and 99 monitor modules. These are polled by the control unit every few seconds and input or output functions communicated to determine sensor status or module function. The main processor determines alarm conditions, sensor status and all devices are monitored for trouble conditions.

Addressable Device Circuit
 Style 4, 6 or 7 Operation
 (set jumper P1 for proper style)
 24VDC nominal
 Wire Resistance-20 ohms/line
 Supervised, Power Limited
 See Owner's Manual for Compatible Devices

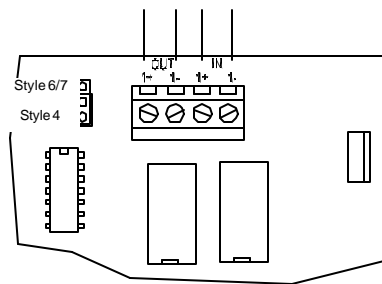

Addressable Device Wiring Diagrams

Proper connections for UL Listed compatible addressable devices are indicated below. Refer also to the instruction sheets packed with each device.

Sensors and modules may be wired together according to several NFPA defined wiring styles. The wiring style that is appropriate for your installation should be determined from the relevant building codes and the Authority Having Jurisdiction.

Typical wiring of a System Sensor addressable device circuit

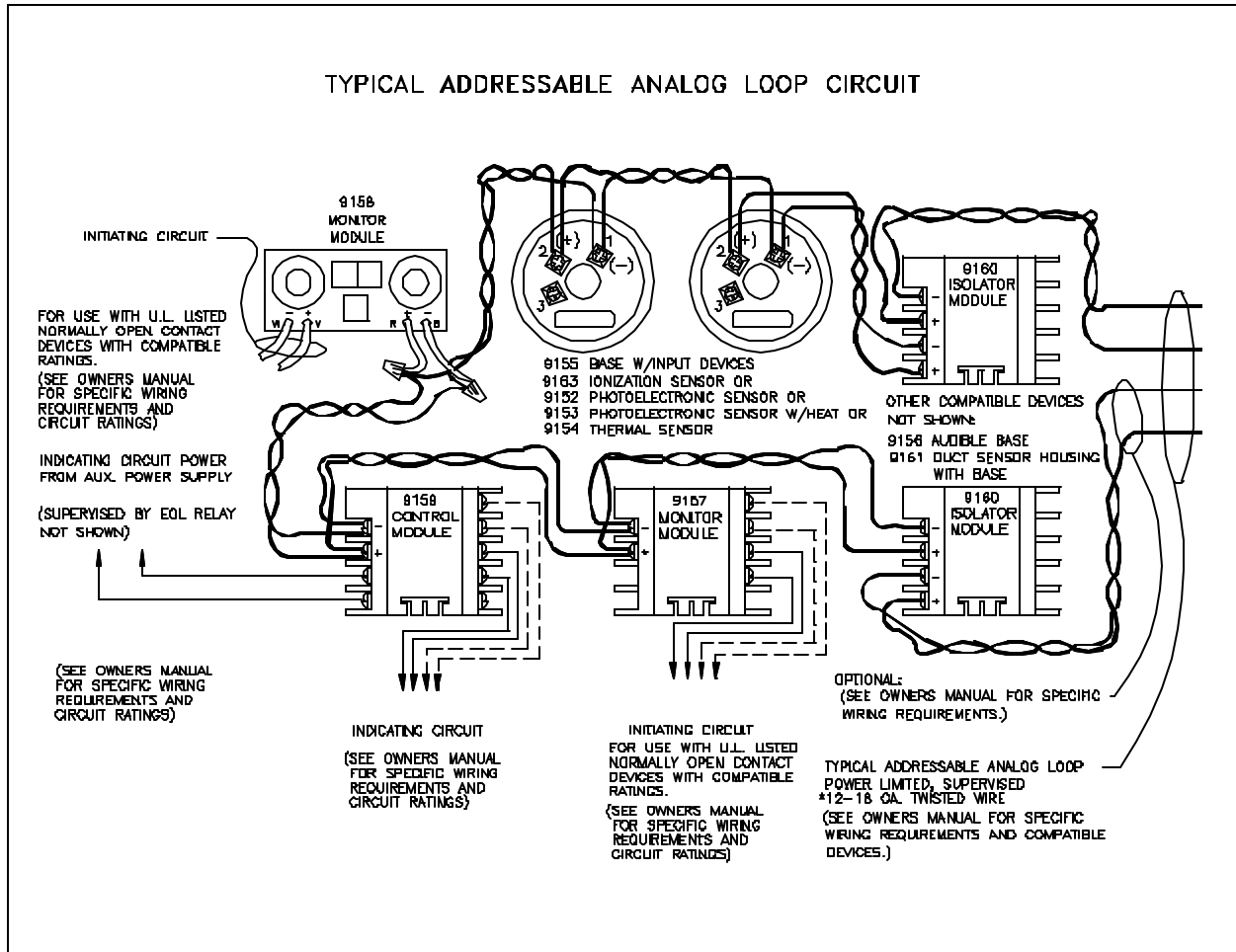

Style 4 wiring permits branching of circuit connections. The control equipment supervises modules because they are active and must respond periodically to the control units interrogation.

ADDRESSABLE DEVICE CIRCUIT
WIRING / OPERATION COMPARABLE TO NFPA STYLE "4"

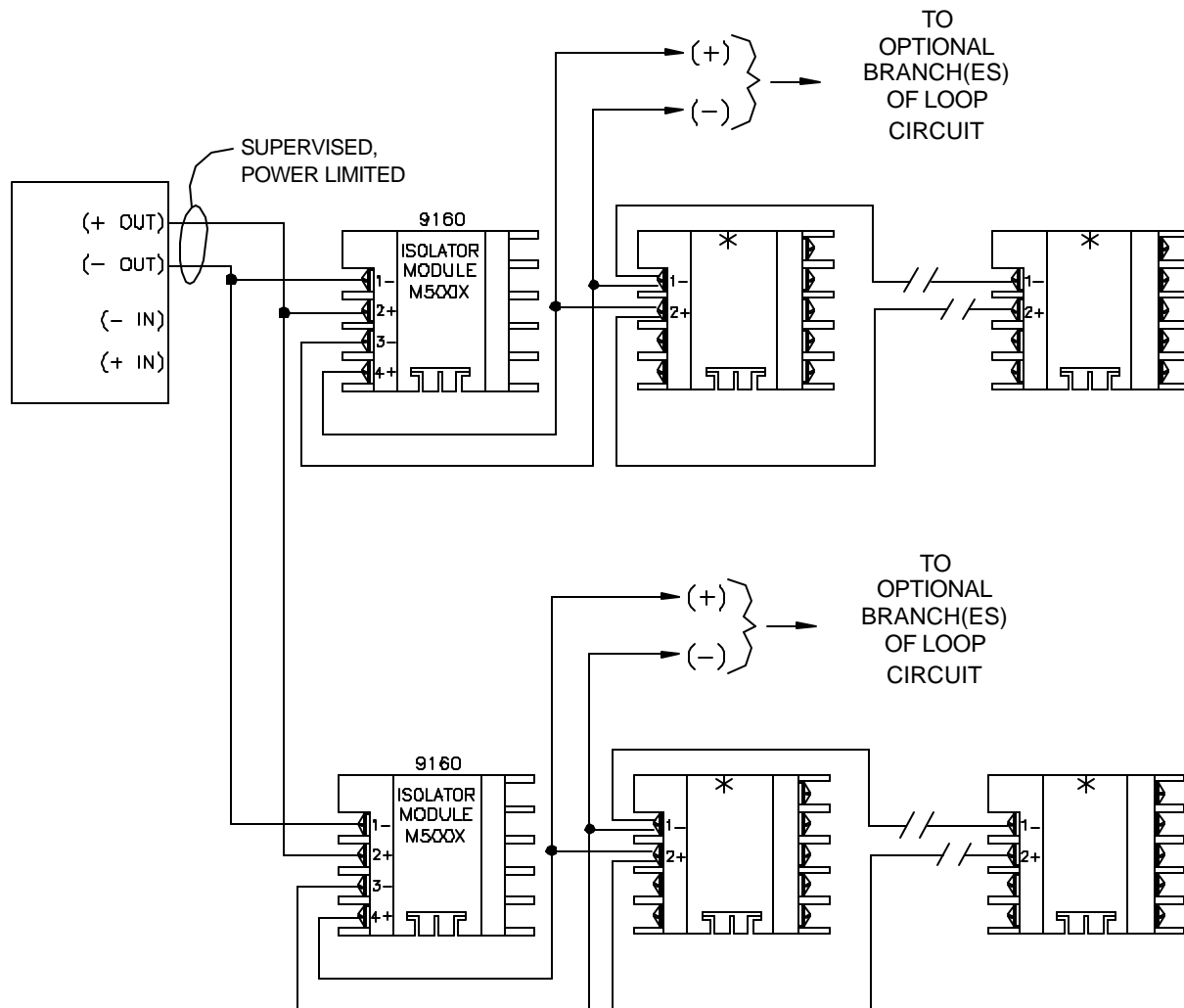

*Note:

Any combination of Sensors, Monitor Modules, or Control Modules up to a maximum of 99 Sensors and 99 Modules. Recommended maximum of 25 devices per Isolator Module.

Style 6 provides redundant communication paths.

ADDRESSABLE DEVICE CIRCUIT
WIRING / OPERATION COMPARABLE TO NFPA STYLE "6"

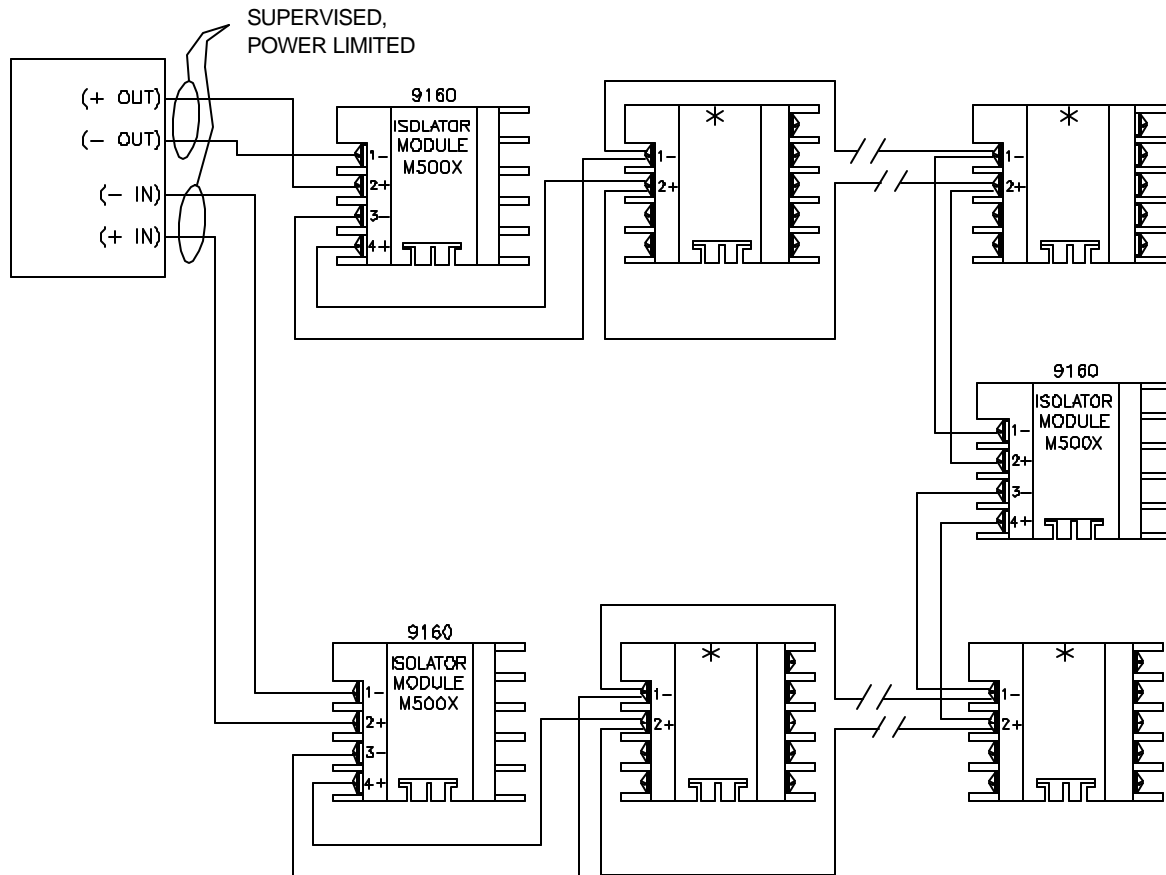

*Note:

Any combination of Sensors, Monitor Modules, or Control Modules up to a maximum of 99 Sensors and 99 Modules. Recommended maximum of 25 devices per Isolator Module.

Style 7 may be used where it is required that a single break or short in the circuit does not cause any modules to stop functioning.

ADDRESSABLE DEVICE CIRCUIT
WIRING / OPERATION COMPARABLE TO NFPA STYLE "7"

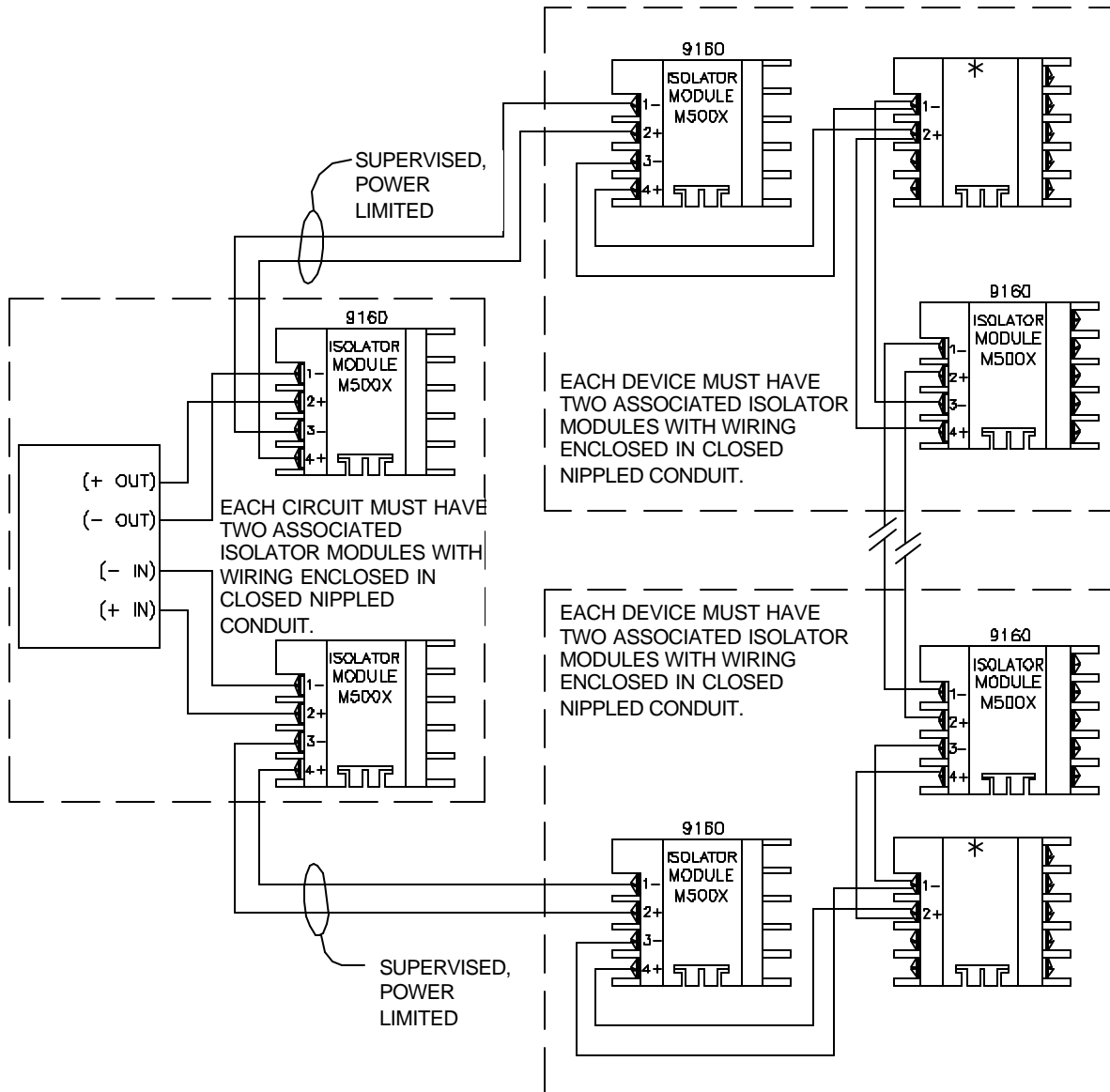

*Note:

Any combination of Sensors, Monitor Modules, or Control Modules up to a maximum of 99 Sensors and 99 Modules. Maximum of 1 device between Isolator Modules.

When using the 9298 or 9299 Isolator Base, it will be wired in place of a 9160 and the addressable sensor shown in the wiring above (one 9160 Isolator is required per sensor with an isolator base).

Addressable/Analog Sensors

8406 Low Profile Photoelectric Sensor with Thermal

The 8406 Low Profile Photoelectric Sensor (System Sensor 2251T) uses an sensor address between 01 and 99 on an addressable device circuit. The 8406 is regularly scanned by the control unit and checked for its current sensor status. The control unit will interpret and respond to the analog data as programmed. Each time the 8406 is scanned the integral red visible LEDs will flash. In the event of an alarm condition the red LEDs will illuminate and latch on. The 8406 allows programmable analog sensitivity with fixed thermal temperature of 135° F. Requires a 9189, 9296 or 9298 base (System Sensor B210LP, B224RB or B224BI).

9152 Photoelectronic Sensor

The 9152 (System Sensor 2551B) uses a sensor address between 01 and 99 on an addressable device circuit. The 9152 is regularly scanned by the control unit and checked for its current sensor status. The control unit will interpret and respond to the analog data as programmed. Each time the 9152 is scanned the integral red visible LEDs will flash. In the event of an alarm condition the red LEDs will illuminate and latch on. The 9152 allows programmable analog sensitivity. Requires a 9155, 9156, 9181, 9297 or 9299 base (System Sensor B501B, B501BH, B501, B524RB or B524BI).

9153 Photoelectronic Sensor with Thermal

The 9153 (System Sensor 2551THR) uses a sensor address between 01 and 99 on an addressable device circuit. The 9153 is regularly scanned by the control unit and checked for its current sensor status. The control unit will interpret and respond to the analog data as programmed. Each time the 9153 is scanned the integral red visible LEDs will flash. In the event of an alarm condition the red LEDs will illuminate and latch on. The 9153 allows programmable analog sensitivity with fixed thermal temperature of 135° F. Requires a 9155, 9156, 9181, 9297 or 9299 base (System Sensor B501B, B501BH, B501, B524RB or B524BI).

9154 or 9182 Thermal Sensor

The 9154 (System Sensor 5551B) or 9182 (System Sensor 5551R) uses a sensor address between 01 and 99 on an addressable device circuit. The 9154 is regularly scanned by the control unit and checked for its current sensor status. The control unit will interpret and respond to the analog data as programmed. Each time the sensor is scanned the integral red visible LEDs will flash. In the event of an alarm condition the red LEDs will illuminate and latch on. The 9154 has a fixed operating temperature of 135° F. The 9182 has a fixed operating temperature of 135° F with rate-of-rise detection. Requires a 9155, 9156, 9181, 9297 or 9299 base (System Sensor B501B, B501BH, B501, B524RB or B524BI).

9163 Ionization Sensor

The 9163 (System Sensor 1551 B) uses a sensor address between 01 and 99 on an addressable device circuit. The 9163 is regularly scanned by the control unit and checked for its current sensor and chamber status. These statuses are reported by device location to the control unit. The control unit will interpret and respond to the analog data as programmed. Each time the 9163 is scanned the integral red visible LEDs will flash. In the case of an alarm condition the red LEDs will illuminate and latch on. The 9163 allows programmable analog sensitivity. Requires a 9155, 9156, 9181, 9297 or 9299 base (System Sensor B501B, B501BH, B501, B524RB or B524BI).

9186 Low Profile Ionization Sensor

The 9186 Low Profile Ionization Sensor (System Sensor 1251) uses an address between 01 and 99 on an addressable device circuit. The 9186 is regularly scanned by the control unit and checked for its current sensor and chamber status. These statuses are reported by device location to the control unit. The control unit will interpret and respond to the analog data as programmed. Each time the 9186 is scanned the integral red visible LEDs will flash. In the case of an alarm condition the red LEDs will illuminate and latch on. The 9186 allows programmable analog sensitivity. Requires a 9189, 9296 or 9298 base (System Sensor B210LP, B224RB or B224BI).

9187 Low Profile Photoelectric Sensor

The 9187 Low Profile Photoelectric Sensor (System Sensor 2251) uses a sensor address between 01 and 99 on an addressable device circuit. The 9187 is regularly scanned by the control unit and checked for its current sensor status. The control unit will interpret and respond to the analog data as programmed. Each time the 9187 is scanned the integral red visible LEDs will flash. In the event of an alarm condition the red LEDs will illuminate and latch on. The 9187 allows programmable analog sensitivity. Requires a 9189, 9296 or 9298 base (System Sensor B210LP, B224RB or B224BI).

NOTE: *The devices are set at the factory for address 00. This is a default code. During installation set address to the predetermined address code.*

9155, 9156 or 9181 Addressable/Analog Bases

The 9155 or 9181 (System Sensor B501B or B501) base is a standard design for use with an addressable/analog sensor. Provides connection to an optional remote LED. The 9181 is flange-less for special mounting applications.

The 9156 (System Sensor B501BH) audible sensor base is designed for use with an addressable/analog sensor. The 9156 provides means to obtain a local audible alarm at the specific sensor location. Once the 9156's associated sensor has latched into the alarm state, the integral horn in the 9156 will sound. It will remain on until the sensor is successfully reset. A regulated power supply is required for the integral horn.

9189 Low Profile Addressable/Analog Base

The 9189 (System Sensor B210LP) Low Profile base is used with the 9186 and 9187 addressable/analog Low Profile sensors. Provides connection to an optional remote LED.

Typical Base Wiring Diagram (9155, 9181 & 9189)

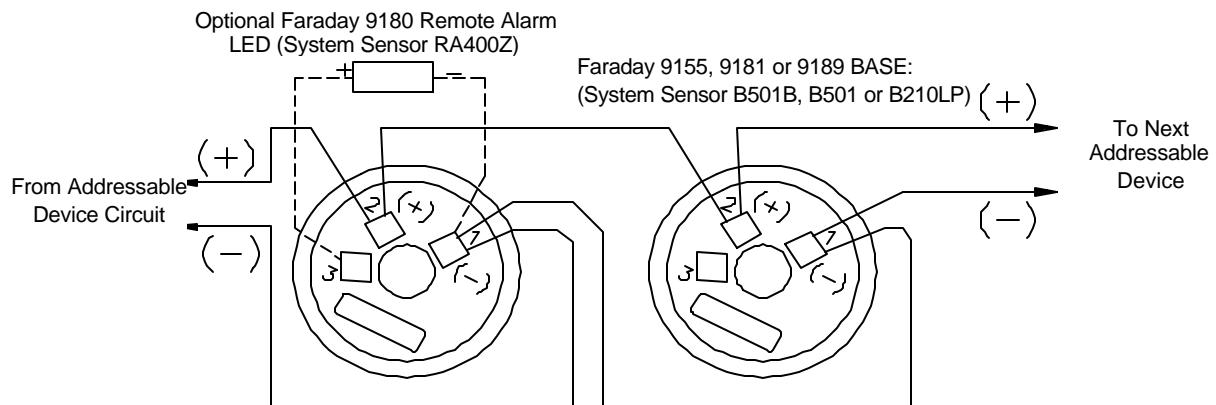

Typical Horn Base Wiring Diagram (9156)

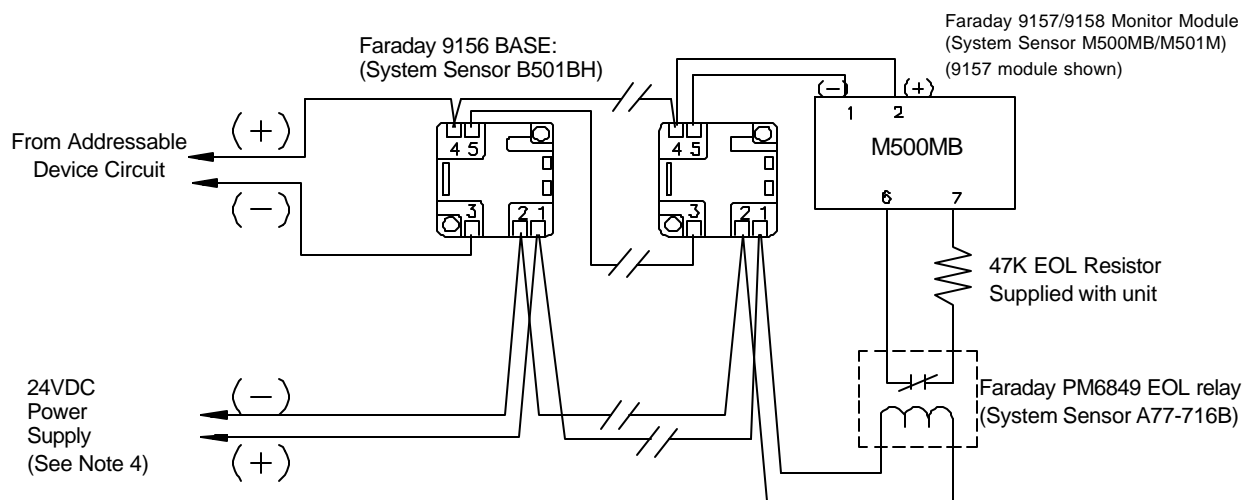

Notes:

1. This wiring diagram shows only general information about this device. For specific wiring and installation information, read the instructions provided with the device.
2. Wire Size: In alarm, no more than 3.0V drop from power supply to end of power supply loop.
3. For power supply supervision use an EOL relay with a 9157 or 9158 monitor module as shown. (Relay contact shown with power applied)
4. From the control unit auxiliary power output or an external 24VDC regulated power supply that must be power limited and listed for Fire Protective Signaling Use.

9296 & 9297 Relay Base

The 9297 (System Sensor B524RB) is designed for use with an addressable/analog sensor and provides an alarm relay contact. The 9296 (System Sensor B224RB) is used with Low Profile sensors.

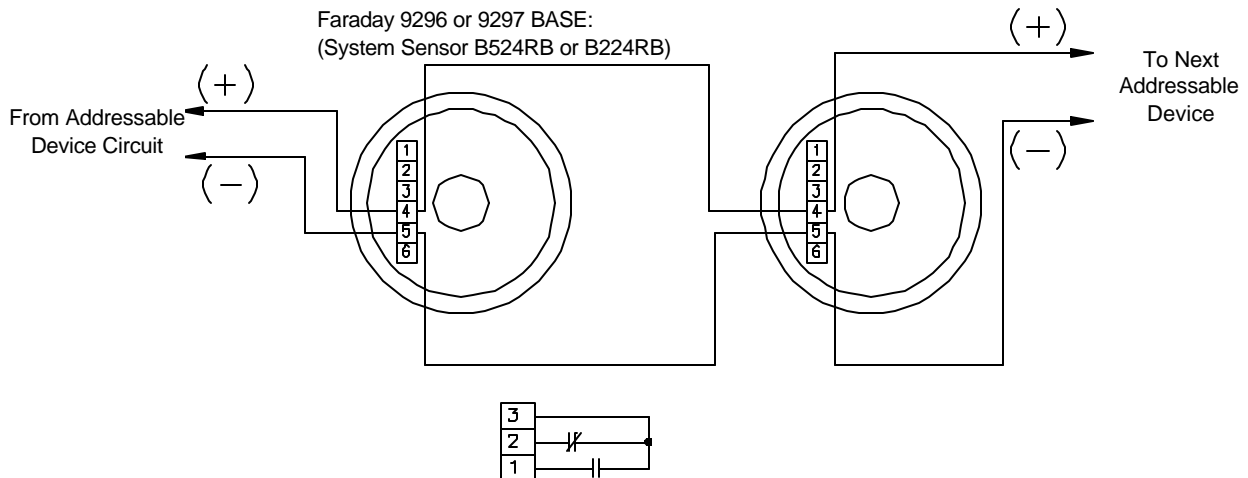

Notes:

1. This wiring diagram shows only general information about this device. For specific wiring and installation information, read the instructions provided with the device.

9298 & 9299 Isolator Base

The 9299 (System Sensor B524BI) is designed for use with an addressable/analog sensor and provides short circuit isolation. The 9298 (System Sensor B224BI) is used with Low Profile sensors.

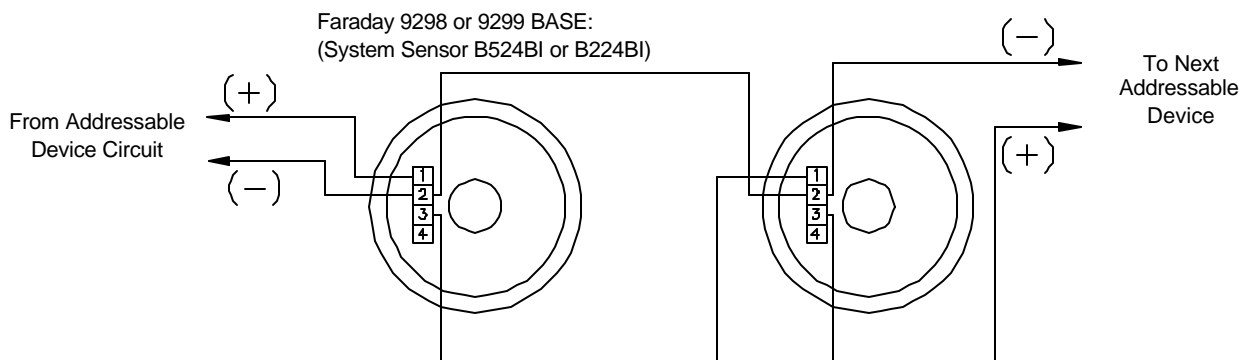

Notes:

1. This wiring diagram shows only general information about this device. For specific wiring and installation information, read the instructions provided with the device.

9161 Duct Housing for Addressable/Analog Sensors

The 9161 (System Sensor DH500AC/DC) is designed for use with an addressable/analog Ion or Photo sensor. The 9161 is designed for 120VAC, 240VAC, 24VAC, or 24VDC to operate auxiliary functions. Two "Form C" relay contacts are available. The LEDs on the sensor illuminate to indicate an alarm. Remote alarm indication is made possible by utilizing the 9180 remote alarm LED unit.

**TYPICAL WIRING DIAGRAM FOR A 9161 DUCT HOUSING
FOR ADDRESSABLE ANALOG SENSOR**

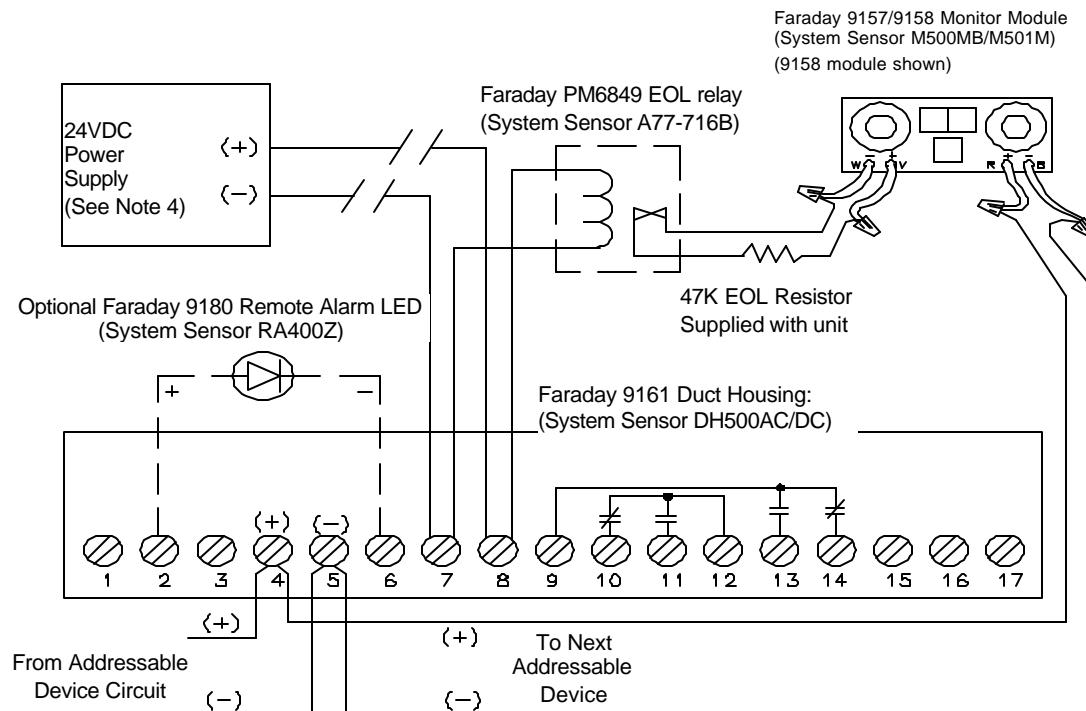

Notes:

1. This wiring diagram shows only general information about this device. For specific wiring and installation information, read the instructions provided with the device.
2. Wire Size: In alarm, no more than 3.0V drop from power supply to end of power supply loop.
3. For power supply supervision use an EOL relay with a 9157 or 9158 monitor module as shown. (Relay contact shown with power applied)
4. From the control unit auxiliary power output or an external 24VDC regulated power supply that must be power limited and listed for Fire Protective Signaling Use.
5. 9180 Remote LED and Auxiliary Control contacts will not function without separate power.
6. Relay contacts are rated at 10 Amps maximum at 30VDC, 10 Amps maximum at 277VAC, 1/2 HP at 240VAC and 360VA at 240VAC.

9179 Duct Housing for Addressable/Analog Sensors

The 9179 (System Sensor DH500) is designed for use with an addressable/analog Ion or Photo sensor. The LEDs on the sensor illuminate to indicate an alarm. Remote alarm indication is made possible by utilizing the 9180 remote alarm LED unit. The 9167 remote test station may be used, if separate power is supplied.

TYPICAL WIRING DIAGRAM FOR A 9179 DUCT HOUSING FOR ADDRESSABLE/ANALOG SENSOR

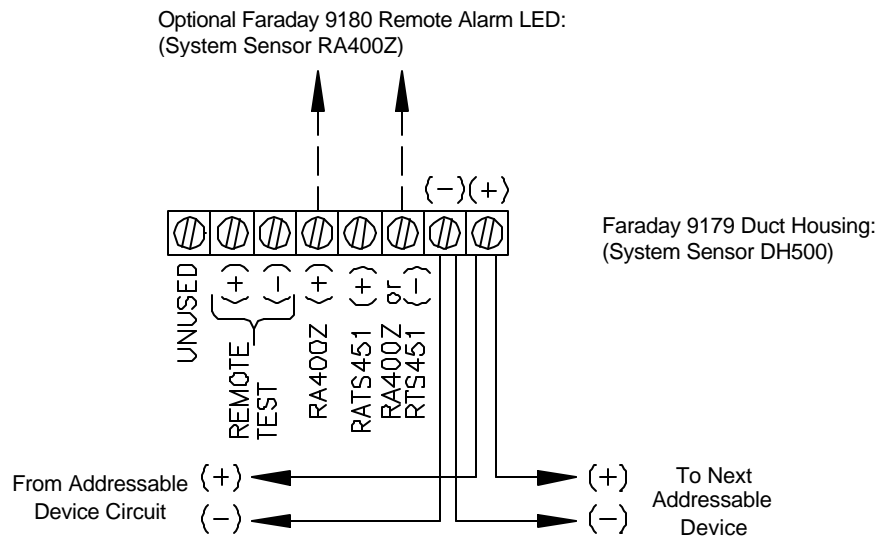

Notes:

1. This wiring diagram shows only general information about this device. For specific wiring and installation information, read the instructions provided with the device.
2. The 9167 remote test station switch will not function without separate power. (See typical wiring diagram for a 9161 duct housing for wiring of separate power with supervision).

Addressable Modules

Zone Monitor Module (9157)

The 9157 (System Sensor M500MB) monitor module provides (1) Style "B" (2-wire) initiating circuit or (1) Style "D" (4-wire) initiating circuit for normally open dry contact fire alarm and supervisory (tamper) devices. The 9157 is designed to mount directly inside a 4" square junction box. The 9157 monitor module may be used to monitor a single unit or "zone" of units of "4-wire" (separately powered) smoke detectors, manual stations, waterflow switches, tamper (supervisory) switches or other dry, normally open contact initiation devices.

The 9157 uses a module address between 01 and 99 on an addressable device circuit. The 9157 module is regularly scanned by the control unit and checked for its current monitored device(s) status (i.e. open (trouble), normal (EOL), shorted (alarm)). Each time the 9157 is scanned the front visible red LED will flash. Once the control unit has received the status data it will interpret and respond to this data as programmed. In the case of an alarm status or Style "D" open circuit, the front visible red LED will illuminate and latch on the appropriate 9157 module(s) until the system is successfully reset.

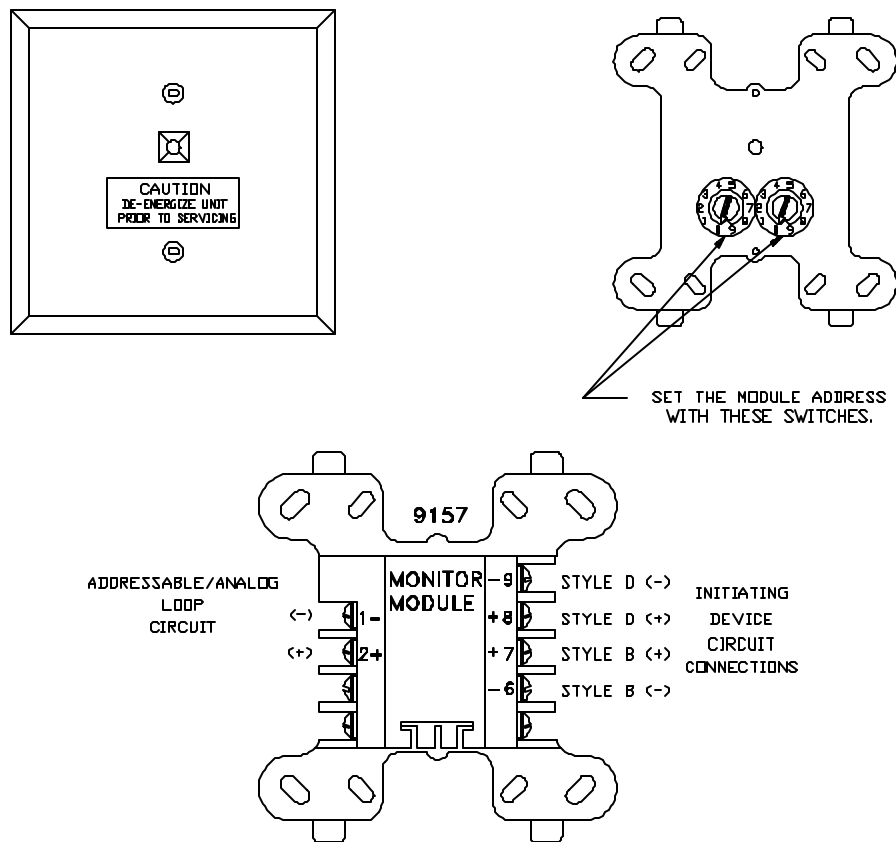

NOTE: The devices are set at the factory for address 00. This is a default code. During installation set address to the predetermined address code.

CONFIGURATION OF 9157 MONITOR MODULE
TYPICAL CONVENTIONAL STYLE "B" ("2-WIRE") CONTACT DEVICE INITIATING CIRCUIT

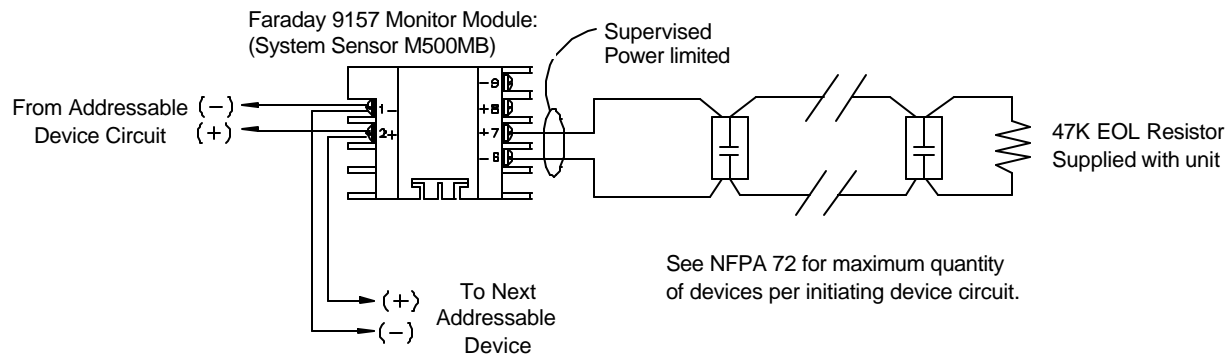

CONFIGURATION OF 9157 MONITOR MODULE
TYPICAL CONVENTIONAL STYLE "D" ("4-WIRE") CONTACT DEVICE INITIATING CIRCUIT

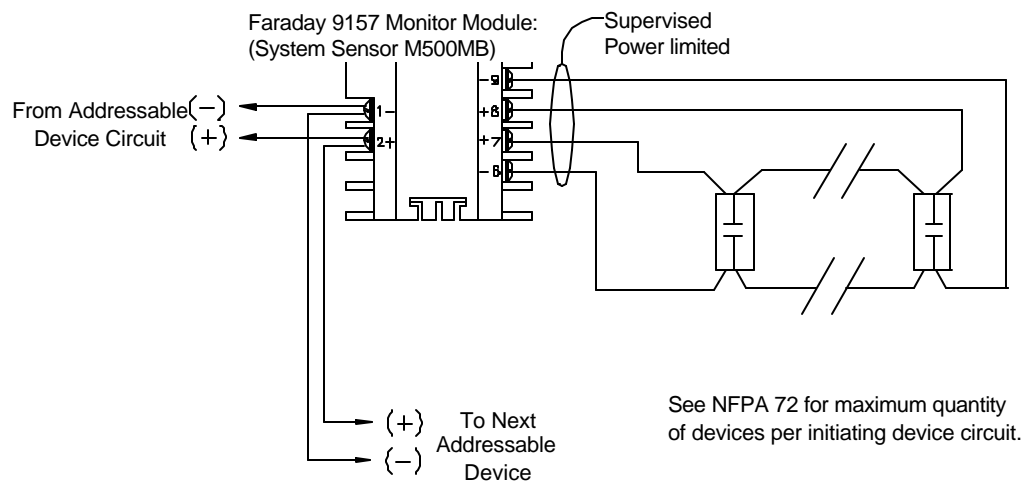

Notes:

1. This wiring diagram shows only general information about this device. For specific wiring and installation information, read the instructions provided with the device.
2. Do not mix Fire & Supervisory (Tamper) Devices on the same initiating device circuit.
3. Initiating Circuit Requirements:

Maximum wire length:	2500 Ft.
Maximum wire resistance:	20 Ohms
Maximum alarm current:	230uA
4. Do not put "2-Wire" (Zone Powered) Smoke Detectors on Monitor Module Initiating loop.
5. See Article 370 of the N.E.C. for proper box depth.

CONFIGURATION OF 9157 MONITOR MODULE
TYPICAL WIRING DIAGRAM FOR CONVENTIONAL
"4-WIRE" (SEPARATELY POWERED) SMOKE DETECTORS STYLE "B" ("2-WIRE")

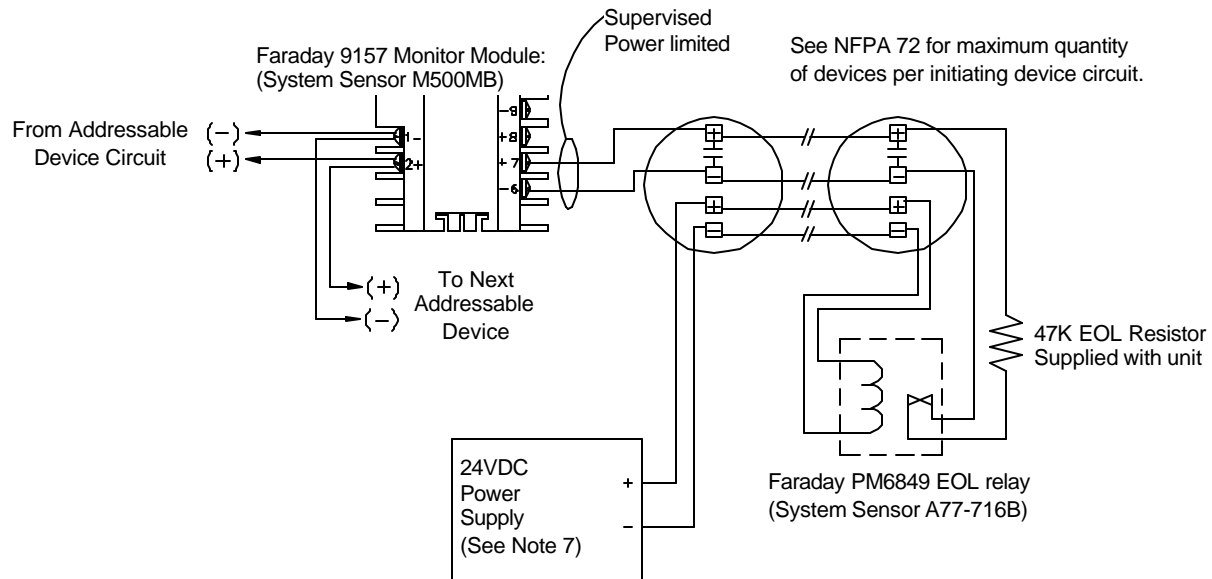

Notes:

1. This wiring diagram shows only general information about this device. For specific wiring and installation information, read the instructions provided with the device.
2. Do not mix Fire & Supervisory (Tamper) Devices on the same initiating device circuit.
3. Initiating Circuit Requirements:
 Maximum wire length: 2500 Ft.
 Maximum wire resistance: 20 Ohms
 Maximum alarm current: 230uA
4. Do not put "2-Wire" (Zone Powered) Smoke Detectors on Monitor Module Initiating loop.
5. See Article 370 of the N.E.C. for proper box depth.
6. For power supply supervision use an E.O.L. relay as shown (relay contact shown with power applied).
7. From the control unit resettable auxiliary power supply output or an external 24VDC regulated power supply that must be power limited and listed for Fire Protective Signaling Use.

**CONFIGURATION OF 9157 MONITOR MODULE
TYPICAL WIRING DIAGRAM FOR CONVENTIONAL
"4-WIRE" (SEPARATELY POWERED) SMOKE DETECTORS STYLE "D" ("4-WIRE")**

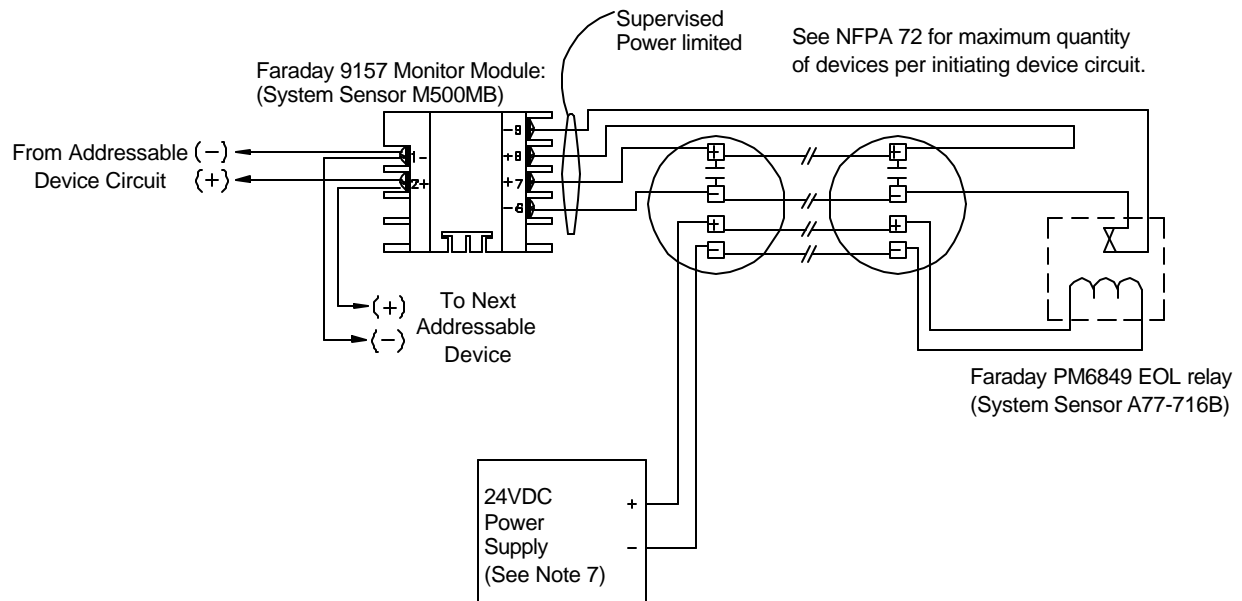
**Notes:**

1. This wiring diagram shows only general information about this device. For specific wiring and installation information, read the instructions provided with the device.
2. Do not mix Fire & Supervisory (Tamper) Devices on the same initiating device circuit.
3. Initiating Circuit Requirements:
 Maximum wire length: 2500 Ft.
 Maximum wire resistance: 20 Ohms
 Maximum alarm current: 230uA
4. Do not put "2-Wire" (Zone Powered) Smoke Detectors on Monitor Module Initiating loop.
5. See Article 370 of the N.E.C. for proper box depth.
6. For power supply supervision use an E.O.L. relay as shown (relay contact shown with power applied).
7. From the control unit resettable auxiliary power supply output or an external 24VDC regulated power supply that must be power limited and listed for Fire Protective Signaling Use.

Device Monitor Module (9158) ("Mini-Monitor")

The 9158 (System Sensor M501M) addressable mini-monitor module provides a Style "B" (2-wire) initiating circuit for normally open dry contact fire alarm and supervisory (tamper) devices. The 9158's small size and light weight design allows it to be installed inside a single gang box, or behind a device being monitored without being rigidly mounted. The 9158 addressable mini-monitor module may be used to monitor a single unit or a "zone" of units of "4-Wire" (separately powered) smoke detectors, manual stations, waterflow switches, tamper (supervisory) switches or other dry, normally open contact initiation devices.

NOTE: "2-Wire" (Zone Powered) Smoke detectors and initiation devices are not compatible.

The 9158 uses a module address between 01 and 99 on an addressable device circuit. The 9158 is regularly scanned by the control unit and checked for its current monitored device(s) status (i.e. open (trouble), normal (EOL), shorted (alarm)). Once the control unit has received the status data, it will interpret and respond to this data as programmed.

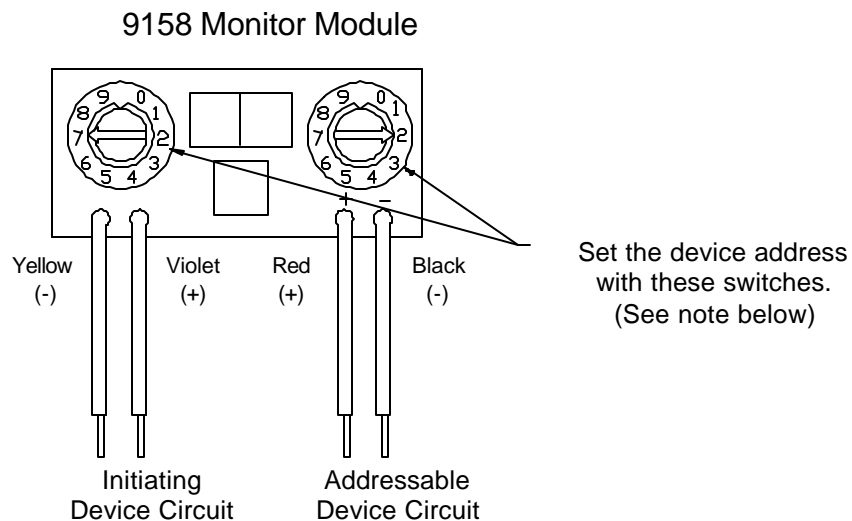

NOTE: The devices are set at the factory for address 00. This is a default code. During installation set address to the predetermined address code.

CONFIGURATION OF 9158 MONITOR MODULE
TYPICAL CONVENTIONAL STYLE "B" ("2-WIRE") INITIATING CIRCUIT

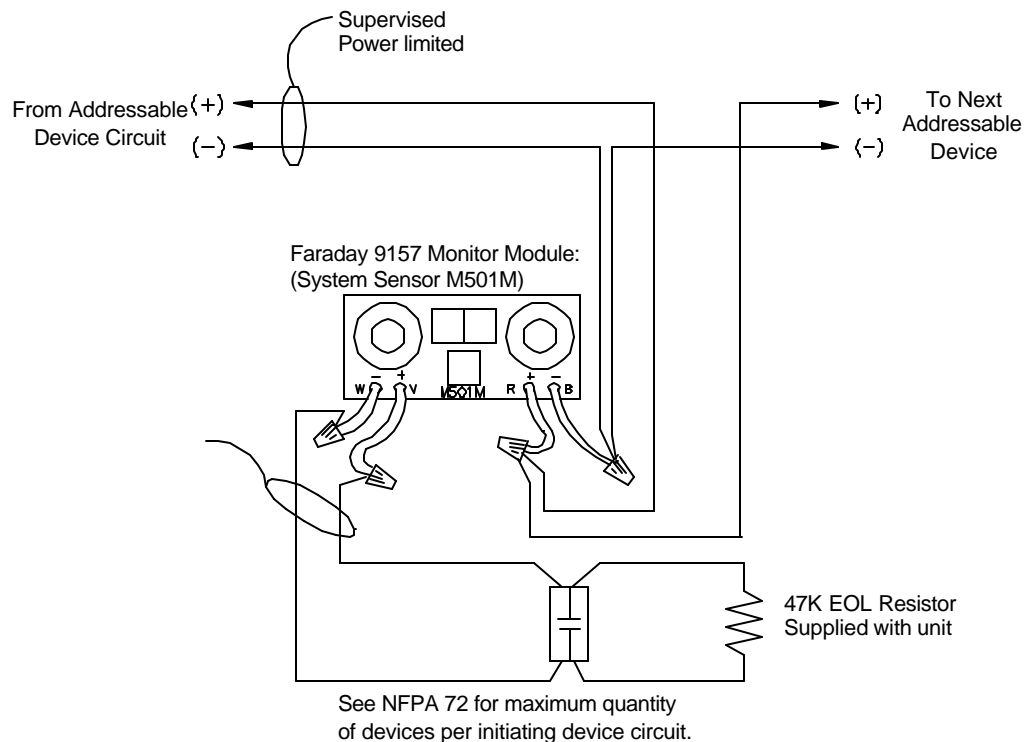

Notes:

1. This wiring diagram shows only general information about this device. For specific wiring and installation information, read the instructions provided with the device.
2. Do not mix Fire & Supervisory (Tamper) Devices on the same initiating device circuit.
3. Initiating Circuit Requirements:
Maximum wire length: 2500 Ft.
Maximum wire resistance: 20 Ohms
Maximum alarm current: 230uA
4. Do not put "2-Wire" (Zone Powered) Smoke Detectors on Monitor Module Initiating loop.
5. See Article 370 of the N.E.C. for proper box depth.

Interface Module (9191)

The 9191 (System Sensor M502M) addressable Interface Module allows the addressable device circuit to interface and monitor two-wire conventional smoke detectors. All two-wire detectors being monitored must be UL compatible with the module. The 9191 is addressed through the communication line of intelligent systems. When the module is interrogated, it transmits the status of one zone of two-wire detectors to an intelligent control unit. Status conditions are reported as normal, open, or alarm. The interface module supervises the zone of detectors and the connection of an external power supply. Two rotary decade switches allow setting module addresses from 01–99. A status LED indicator is provided and is controlled by code command from the control unit. The module provides a magnetically activated test switch for testing the module's electronics and connections to the control unit.

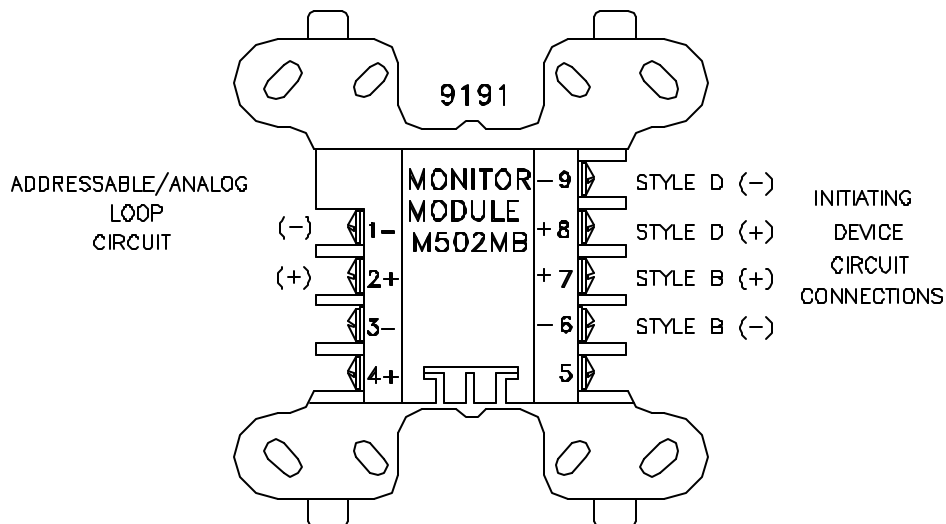
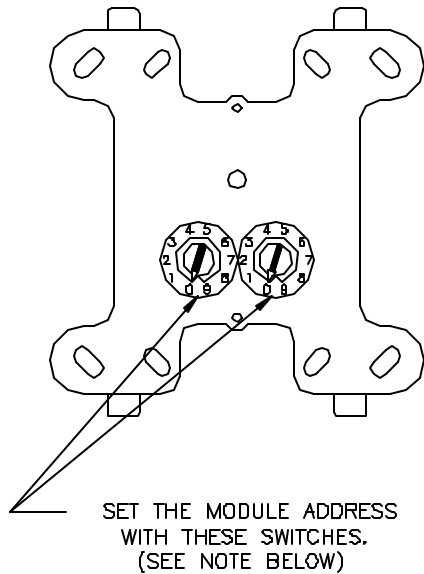
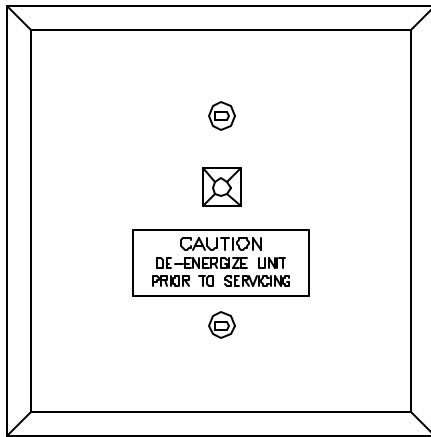

NOTE: The devices are set at the factory for address 00. This is a default code. During installation set address to the predetermined address code.

CONFIGURATION OF 9191 MONITOR MODULE
TYPICAL CONVENTIONAL STYLE "B" ("2-WIRE") CONTACT DEVICE INITIATING CIRCUIT

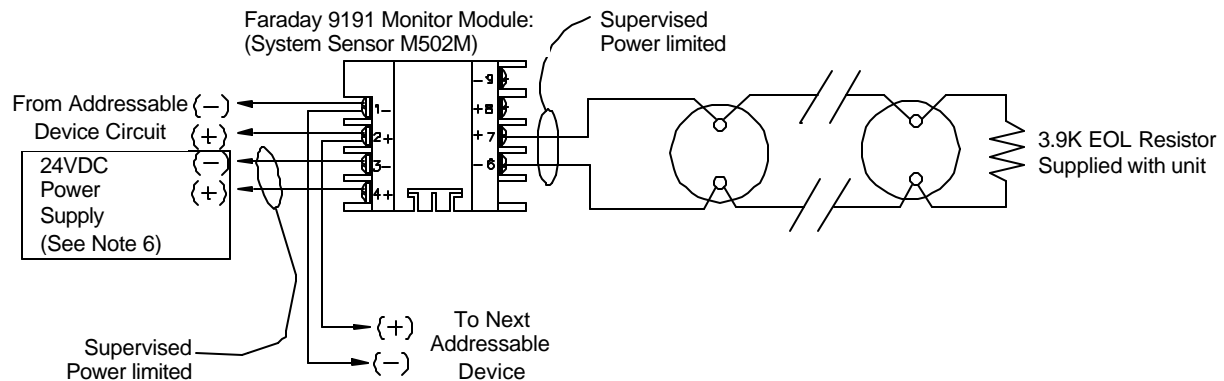

CONFIGURATION OF 9191 MONITOR MODULE
TYPICAL CONVENTIONAL STYLE "D" ("4-WIRE") CONTACT DEVICE INITIATING CIRCUIT

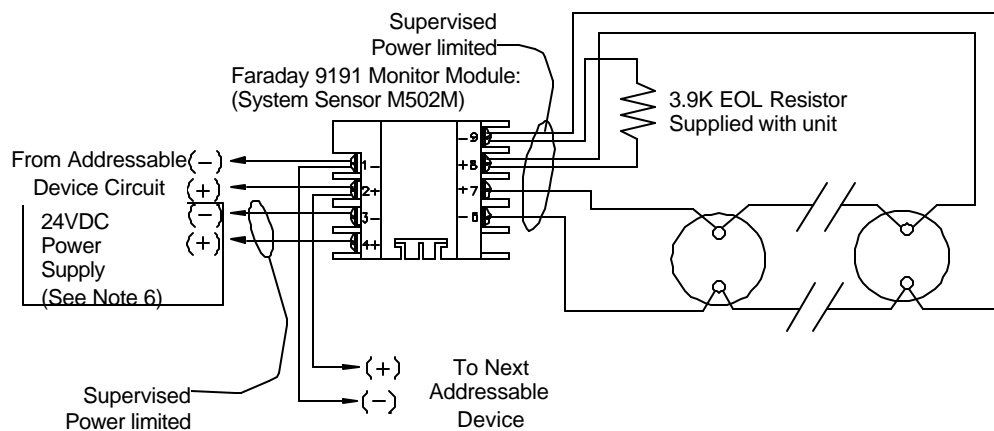

Notes:

1. This wiring diagram shows only general information about this device. For specific wiring and installation information, read the instructions provided with the device.
2. Do not mix Fire & Supervisory (Tamper) Devices on the same initiating device circuit.
3. Initiating Circuit Requirements:
 Maximum wire resistance: 25 ohms
 Maximum alarm current: 92mA
4. Use only UL compatible "2-Wire" (Zone Powered) Smoke Detectors listed in the installation instructions.
5. See Article 370 of the N.E.C. for proper box depth.
6. From the control unit resettable auxiliary power supply output or an external 24VDC regulated power supply that must be power limited and listed for Fire Protective Signaling Use.

Control Module (9159)

The 9159 (System Sensor M500CH) addressable control module provides (1) Style "Y" (2-Wire) polarity reversal notification appliance circuit or (1) "4-Wire" Class "A" (Style "Z") polarity reversal notification appliance circuit or (1) dry form "C" contact output format. The selection of any (1) of these formats per module can be made in the field via an integral programming tab. The 9159 is designed to mount directly inside a 4" square junction box. When the 9159 control module is used drive conventional polarized appliances and auxiliary devices, the operating power for the devices must be wired to the 9159 separately from an auxiliary power supply. The separate power circuit is then supervised by an E.O.L. and monitor module combination relay in a similar fashion as a "4-Wire" (separately powered) conventional smoke detector power circuit.

The 9159 uses a module address between 01 and 99 on an addressable device circuit. The 9159 is regularly scanned by the control unit and checked for its monitored device(s) status (i.e. open (trouble), normal (EOL), shorted (trouble)). Each time the 9159 is scanned the front visible red LED will flash. Once the control unit has received alarm status data it will interpret and respond to the data as programmed thus activating any predetermined 9159 control module(s). When an associated 9159 operates, its red LED will illuminate and the module will latch into the operated mode until reset.

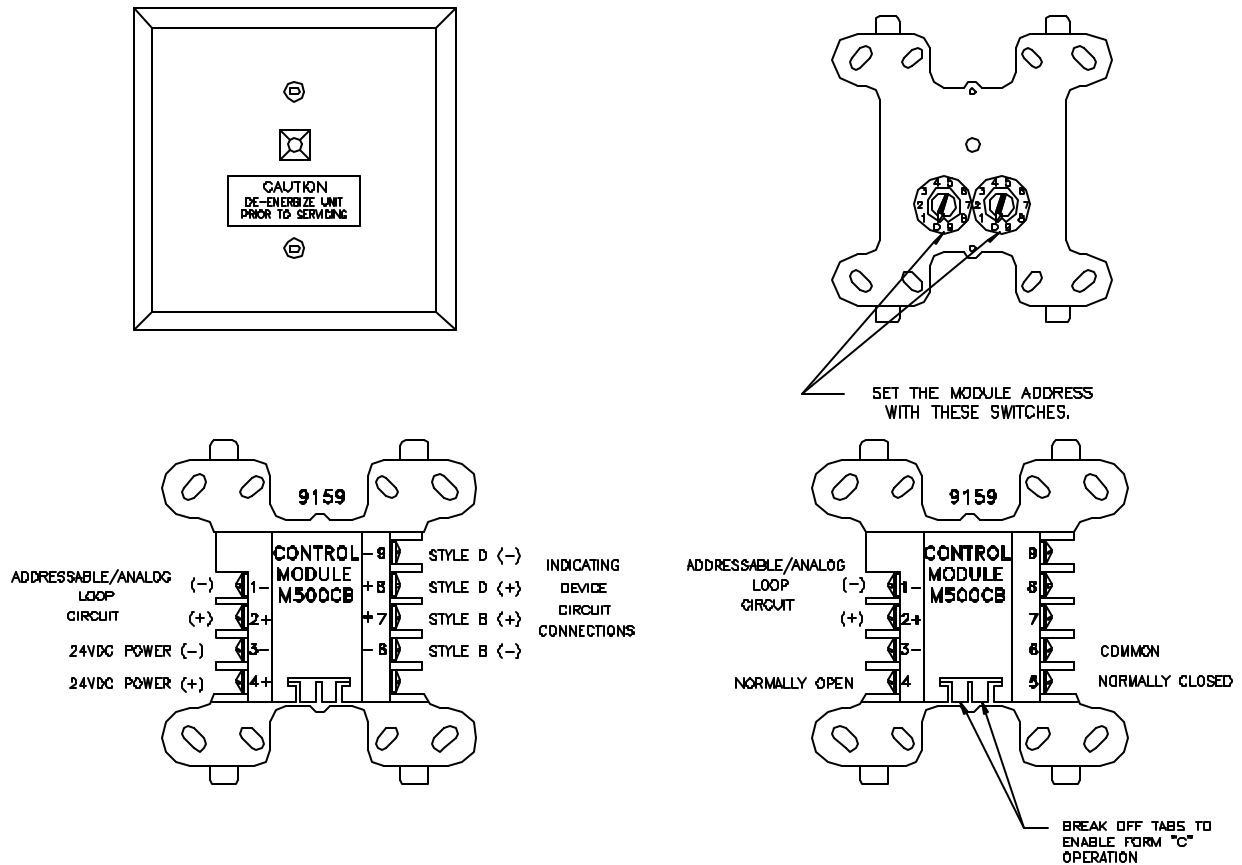

NOTE: The devices are set at the factory for address 00. This is a default code. During installation set address to the predetermined address code.

CONFIGURATION OF 9159 CONTROL MODULE
 TYPICAL CONVENTIONAL STYLE "Y" ("2-WIRE") NOTIFICATION APPLIANCE CIRCUIT

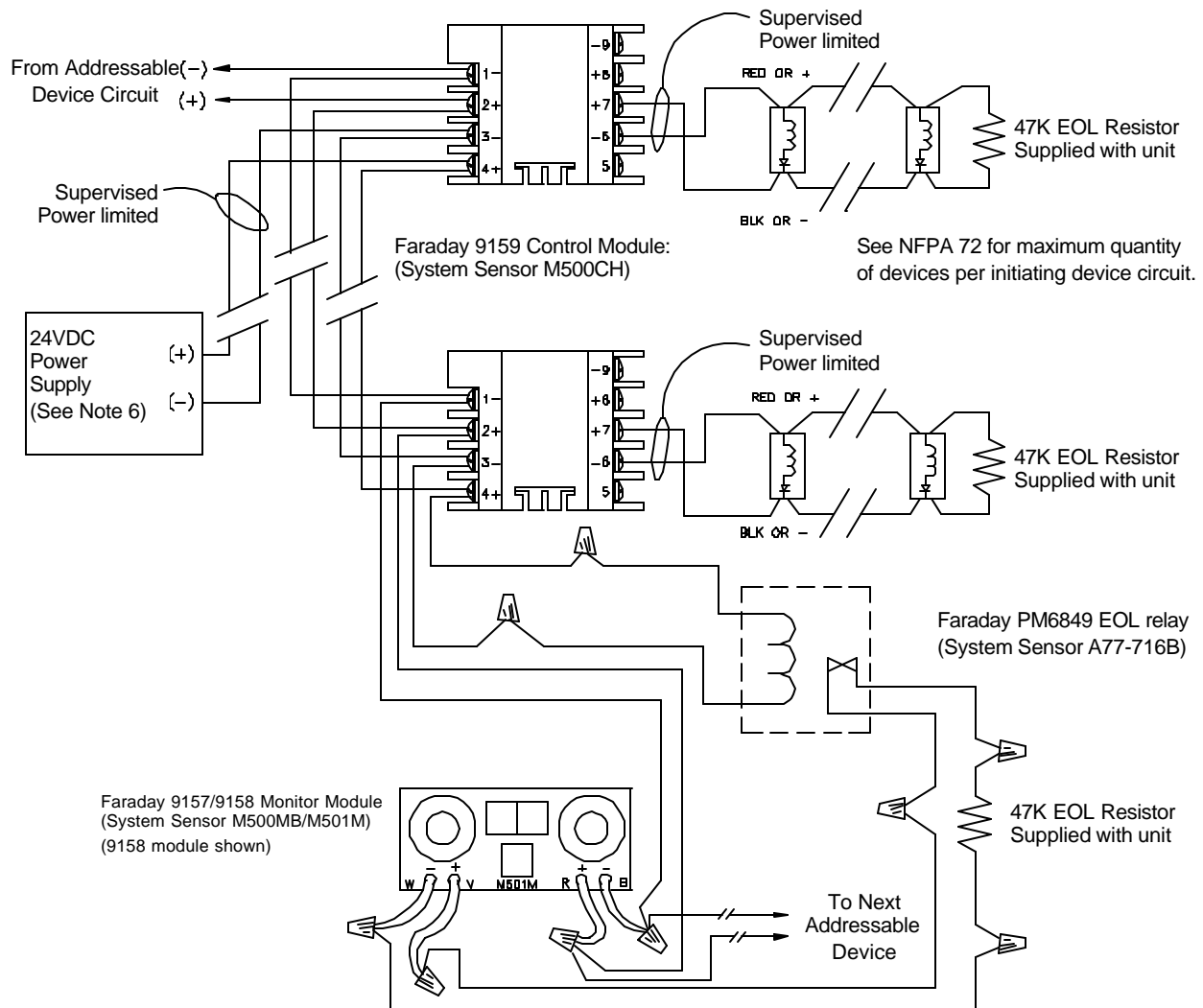

Notes:

1. This wiring diagram shows only general information about this device. For specific wiring and installation information, read the instructions provided with the device.
2. See owners manual for compatible appliances.
3. Notification Appliance Circuit Ratings:
 Maximum alarm current: 1.0A
 Maximum wire voltage drop: 1.9V
4. See Article 370 of the N.E.C. for proper box depth.
5. For power supply supervision use an E.O.L. relay as shown (relay contact shown with power applied).
6. From the control unit auxiliary power supply output or an external 24VDC regulated power supply that must be power limited and listed for Fire Protective Signaling Use.

CONFIGURATION OF 9159 CONTROL MODULE
 TYPICAL CONVENTIONAL STYLE "Z" ("4-WIRE") NOTIFICATION APPLIANCE CIRCUIT

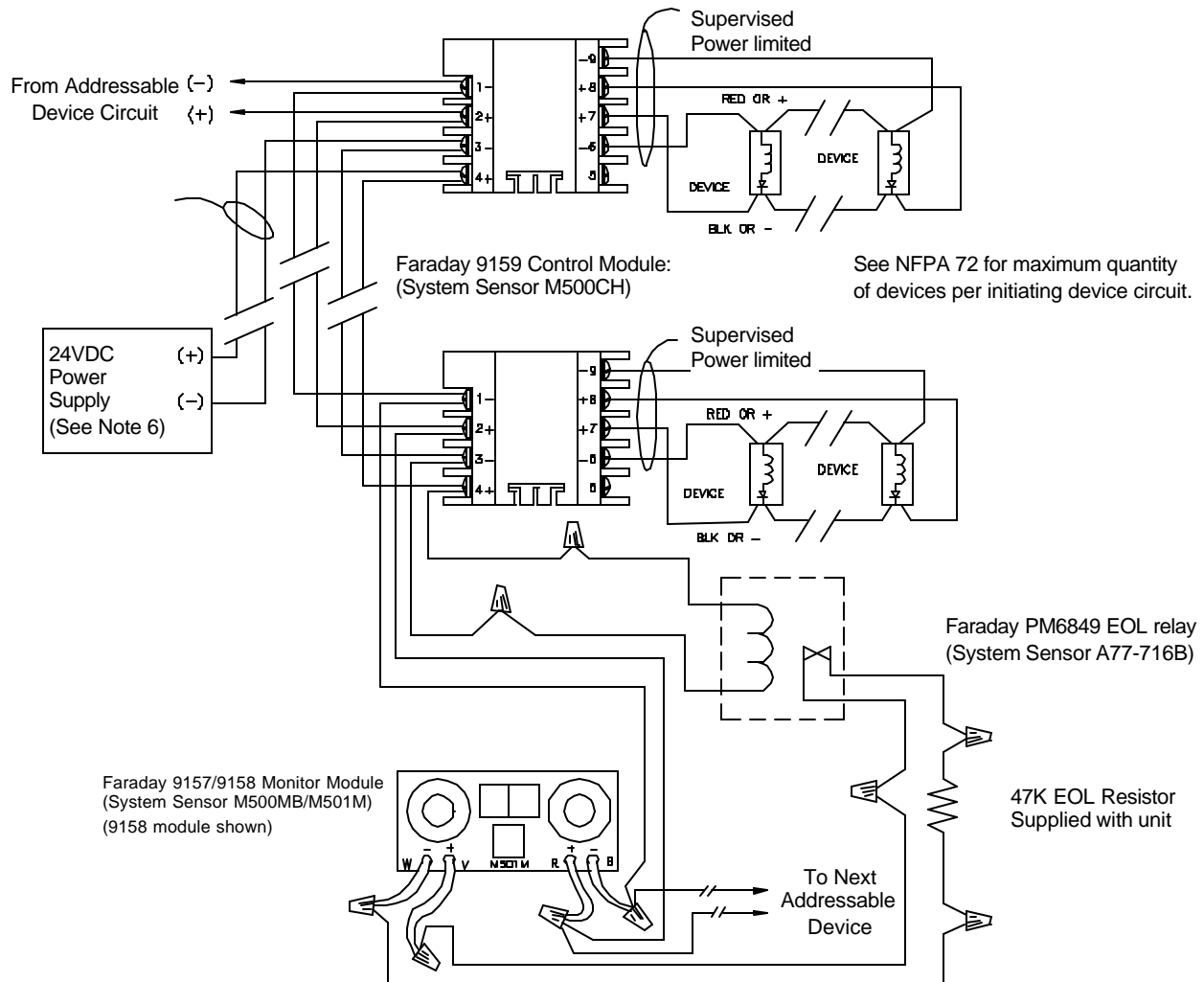

Notes:

1. This wiring diagram shows only general information about this device. For specific wiring and installation information, read the instructions provided with the device.
2. See owners manual for compatible appliances.
3. Notification Appliance Circuit Ratings:
 Maximum alarm current: 1.0A
 Maximum wire voltage drop: 1.9V
4. See Article 370 of the N.E.C. for proper box depth.
5. For power supply supervision use an E.O.L. relay as shown (relay contact shown with power applied).
6. From the control unit auxiliary power supply output or an external 24VDC regulated power supply that must be power limited and listed for Fire Protective Signaling Use.

CONFIGURATION OF 9159 CONTROL MODULE
TYPICAL DRY FORM "C" CONTACT OUTPUT

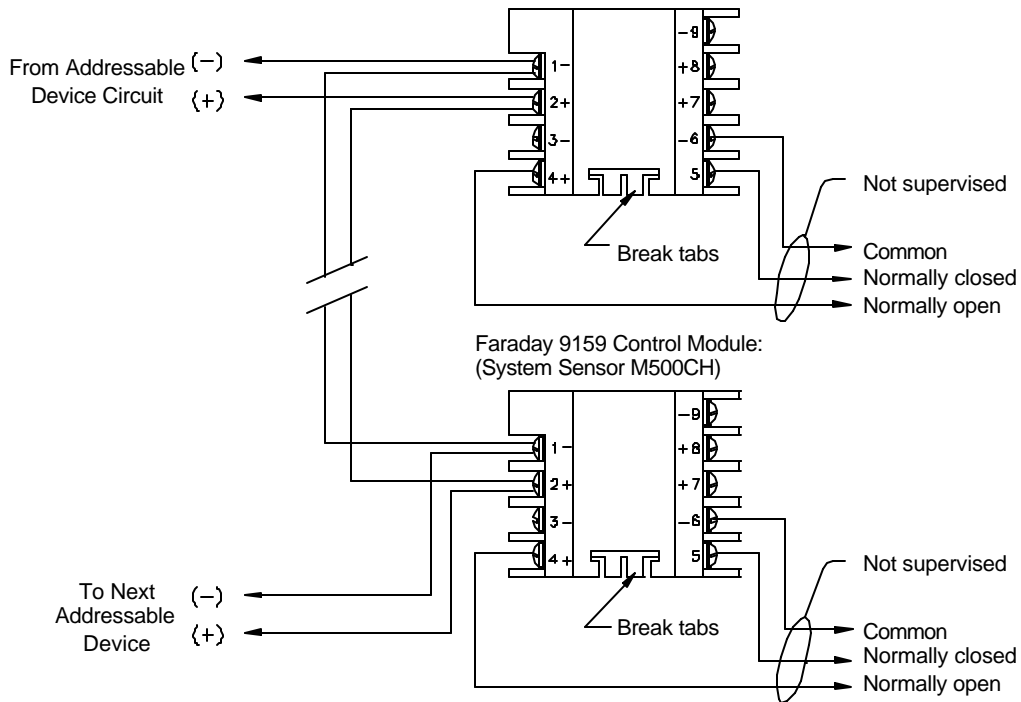

Notes:

1. This wiring diagram shows only general information about this device. For specific wiring and installation information, read the instructions provided with the device.
2. Relay contact ratings:
 Resistive: 2 A., 30VDC
 Inductive: 1 A., 30VDC (0.6pf)
 0.3A., 110VDC (0.35pf)
 0.3 A., 120VAC (0.35pf)
3. See Article 370 of the N.E.C. for proper box depth.

Isolator Module (9160)

The 9180 (System Sensor M500X) addressable device circuit isolator module provides the circuitry to automatically open and thus "isolate" a branch or section of an addressable device circuit. This isolation will occur when the 9160 senses a short condition after its position on the circuit. By isolating the shorted portion of the circuit the control unit will still be able to communicate with and monitor devices not involved with the faulted section or branch of the addressable device circuit.

During normal operation the red scan/shorted LED will flash several times a minute. In the event that the monitored portion becomes shorted the red scan/shorted LED will latch on steady and the associated protected circuit portion will be automatically disconnected from the system and a defined trouble condition will be reported to the control unit. Once the shorted condition has been removed the 9160 module will automatically unlatch thus restoring normal operations between it, its monitored circuit portion, and the rest of the system.

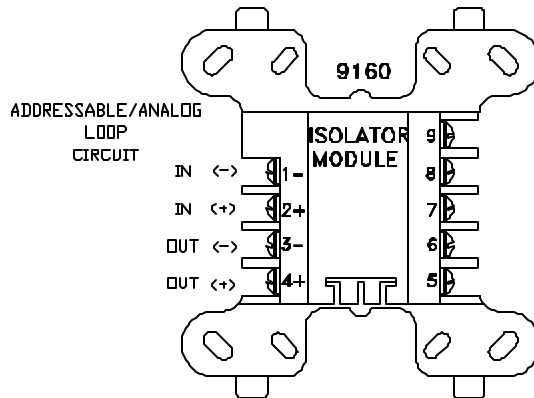
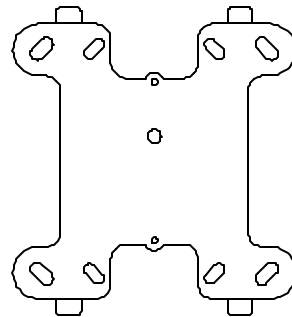
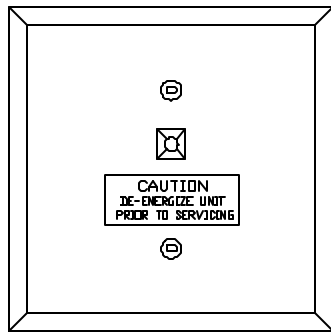

This page is intentionally blank.

VI. PROGRAMMING THE CONTROL UNIT

MAIN BOARD JUMPER

Factory setting is shown.

P1 – Addressable Device Circuit Wiring Style

 Style 6/7

Style 4

KEYPAD PROGRAMMING

Customized programming of the 12100 control unit may be accomplished through a keypad included in the control unit. A sixteen-key, telephone-style keypad mounts on the front panel within the cabinet. The keypad may also be easily removed if desired. See the Faraday 447064 Programmer's Manual for detailed information of system programming.

PROGRAMMING SECURITY

The following levels of security protect the system from unauthorized use:

- User – Locked Door
- Maintenance – Locked Door and 4-digit Maint Password
- Technician – Locked Door and 5-digit Tech Password

The User and Maintenance Levels are also accessible from the Remote LCD Annunciators.

This page is intentionally blank.

VII. MAINTENANCE

GENERAL

- Device sensitivity may be read out and alarm thresholds controlled on a per-point basis, as well as setting overall percent obscuration and day/night variations. Individual points may also be disabled for service.

To perform these functions on the unit, enter the 4-digit maintenance password into the control unit or LCD annunciator. When the menu is displayed, select the desired function or sub-function and press the appropriate operating button. When the function is complete, the menu will provide a command for exiting the maintenance mode.

Note that any abnormal condition, such as disabled points, will report a trouble. Confirmation of disabling or re-enabling a point is required to complete the action, but acknowledgment of the trouble is not required, since it results from operator action.

Activation of an alarm condition or a timeout after no button activity terminates Maintenance mode.

- The system may automatically scan the operating points and report to a printer, facilitating NFPA 72 test requirements. The control unit may perform this scan once a day, with the time selectable by the user.

To initiate a non-programmed automatic test cycle, enter the 4-digit maintenance password into the control unit or LCD annunciator. When the menu is displayed, select Auto-test and press the associated switch. The Auto-test cycle will be completed and the control unit returns to normal. Results will be displayed on the display (anomalies only) or the printer (full data) according to the selected mode.

- The system will automatically monitor drift of quiescent sensor output levels and report a maintenance alert if a preset level is passed, or if a sensor drifts too quickly. This maintenance alert is annunciated as a trouble.
- The system may be programmed to report the number of times the alarm verify function is initiated by device, time of day, and/or day of week, allowing location of environmental problems. This datum is available on the display as described in paragraph 1 above.
- The system may be programmed to alert the operator when scheduled maintenance is required.
- A 2000 event history is maintained, with all events available for chronological review at the operator level. This history may be cleared only with the Tech Level Code. For details on included data and use of the history, see operation instructions.

To clear history when data has been read out and restoration of memory space is desired. Activate maintenance mode as described above and follow menu instructions for clearing the event history.

QUICK TEST

CAUTION: If the control unit has remote connections to the Fire Department or other monitor, be sure to disable the remote signals and notify the remote monitoring station before performing test operations, since an off-normal condition will be indicated.

Quick test is possible in one of two modes, (silent or audible) and is selectable on a per-zone basis. Any number of zones may be placed into test at the same time, but only one mode of quick test operation is possible for the whole system at one time. Points not in quick test operate normally. Quick test operation initiates a system trouble condition.

In the silent mode, all alarm outputs are disabled and only the front panel indications and remote annunciator LEDs operate. In the audible mode all system sounders will sound momentarily as each or device is alarmed.

The system maintains a counter of the number of activation's during the quick test and reports this value when quick test mode is exited.

Quick test terminates into alarm if more than one device activates simultaneously, or if a device does not return to normal after being activated within a configurable length of time.

Quick test terminates automatically into normal standby mode using a timer. The value of the timer is configurable. The timer can be configured to limit the total time of the quick test (i.e. the timer is started only when quick test is entered), or to limit the time between device activation's (i.e. the timer is re-started after each activation).

Alarm activation's that occur in a system or zone in quick test or by a point in quick test cause the event to be logged and printed. No other action is taken.

To initiate quick test, enter maintenance mode as described above and follow menu instructions to configure and initiate the test.

Initiation of General Evacuation from the control unit, an RS485 LCD Annunciator, or an RS485 Remote Processor causes termination of quick test and starts the normal alarm sequence.

Quick test may be terminated by a menu selection or by timeout (set at 5 to 30 minutes) from the last test activation. Timeout system reactivation is annunciated by a 1/2 second on, 1/2 second off pattern from system sounders programmed for drill use. A device in alarm condition when quick test is exited causes the normal alarm sequence.

NOTE: *When any problem is observed with the system, refer to the troubleshooting chart in Appendix C. For any required service, contact a factory-authorized representative.*

VIII. APPENDIX-A: REFERENCE DATA

This appendix provides reference for the following topics:

- Wire selection guides
- Battery size calculations

WIRE SELECTION GUIDES

Resistance of Solid Copper Wire

AWG	Ohms per Thousand Feet*
18	8.08
16	5.08
14	3.19
12	2.01

*NEC Chapter 9, Table 8.

Notification Appliance Circuit Wire Selection Guide

Each Notification Appliance Circuit must not have a voltage drop greater than 1 volt. The following chart is based on the following premises:

- The entire load is at the end of the wire run (worst case).
- Resistance is of solid copper wire

Contact your local distributor or the factory if further information is needed in your circumstances.

Maximum Wire Loop Distance (Feet)

Signal Load (A)	18 AWG	16 AWG	14 AWG	12 AWG
0.1	1,237	1968	3134	4975
0.25	495	787	1253	1990
0.5	247	393	626	995
0.75	165	262	417	663
1.0	123	196	313	497
1.25	99	157	250	398
1.5	82	131	208	331

Addressable Device Circuit Wire Selection Guide

Each addressable device circuit must meet the following requirements:

- Total loop resistance - 40 ohm maximum.
- Total loop capacitance - 0.28uF maximum (56pF/ft. max.)
- Twisted pair wire.
- Unshielded cable.
- Low capacitance cable.
- High velocity of propagation cable - 60% minimum.
- Each loop runs separate from all other circuits.
- Run + out and - out separately from + in and - in.
- Different models or types of cable should not be in the same loop.

Maximum Wire Loop Distance (Feet)

(Includes all branches of a Style 4 loop)

Wire size:	18AWG	16AWG	14AWG	12AWG
Wire length:	6150	9750	10,000	10,000
Twisted pair cable length:	3075	4875	5,000	5,000

BATTERY SIZE CALCULATIONS

				Standby Current (A.)	Alarm Current (A.)
12100 Control Unit				0.110	0.200
12103 RS232 Board	Standby	0.008	0.008	+	NA
	Alarm	0.008	0.008	NA	+
12105 DACT Board	Standby	0.038	0.038	+	NA
	Alarm	0.054	0.054	NA	+
12506 Remote Annunciator	Standby	0.020	X =	+	NA
	Alarm	0.030	X =	NA	+
12507 Serial Relay Unit	Standby	0.010	X =	+	NA
	Alarm	0.170	X =	NA	+
12508 Serial Relay Extender	Standby	0.000	X =	+	NA
	Alarm	0.160	X =	NA	+
12509 Serial Annunciator Unit	Standby	0.015	X =	+	NA
	Alarm (note 5)	0.040	X =	NA	+
12510 Serial Annunciator Extender	Standby	0.005	X =	+	NA
	Alarm (note 5)	0.000	X =	NA	+
4-wire Smoke Detectors					
Catalog #	Quantity	X Current (A.)			
	Standby	X	=	+	NA
	Alarm	X	=	NA	+
	Standby	X	=	+	NA
	Alarm	X	=	NA	+
End of Line Relay					
Catalog #	Quantity	X Current (A.)			
		X	=	+	+
Notification Appliances					
Catalog #	Quantity	X Current (A.)			
		X	=	NA	+
		X	=	NA	+
		X	=	NA	+
		X	=	NA	+
Other			=	+	+
TOTAL					

Total Standby Current (from above)	Hours of Standby Required per NFPA 72 Standard (4, 24 or 60)	AH for Standby
A.	x _____ Hours	=

Total Alarm Current (from above)	5 Minutes of Alarm Operation per NFPA 72 Standard*	AH for Alarm
A.	x 0.33 Hours	=

A.H. for Standby	A.H. for Alarm	Calculated A.H.	De-rating Factor	A.H. Required Battery Capacity
	+	=	X 1.25	=

Notes:

1. An additional multiplier is included to compensate for the higher discharge rate in alarm. Battery capacity decreases with age.
2. A 4-year old battery can lose up to 50% of its capacity. Compensations should be made to allow for this loss.
3. The Standby current + Alarm current must never exceed 3.0 Amps
4. The following states the maximum standby current allowed using a 38 AH battery set:
60 hours of standby time is 0.5 Amps
24 hours of standby time is 1.2 Amps
5. Does not include lamp or LED current, add separately

This page is intentionally blank.

IX. APPENDIX-B: COMPATIBLE DEVICES

COMPATIBLE DEVICES FOR ADDRESSABLE DEVICE CIRCUITS

Addressable Sensors

Faraday Cat. No.	System Sensor P/N	Description
8406	2251T	Photoelectric Addressable/Analog Sensor w/Thermal – Low Profile
9152	2551HR	Photoelectric Addressable/Analog Sensor
9153	2551BT	Photoelectric Addressable/Analog Sensor w/Thermal
9154	5551B	Thermal Addressable/Analog Sensor, Fixed
9163	1551B	Ionization Addressable/Analog Sensor
9182	5551R	Thermal Addressable/Analog Sensor, Fixed & Rate of Rise
9186	1251	Ionization Addressable/Analog Sensor - Low profile
9187	2251	Photoelectric Addressable/Analog Sensor - Low profile

Sensor Bases

Faraday Cat. No.	System Sensor P/N	Description
9155	B501B	Addressable/Analog Sensor Base
9156	B501BH	Addressable/Analog Sensor Base w/Horn
9161	DH500AC/DC	Duct Housing with Addressable/Analog Sensor Base With Auxiliary Contacts
9179	DH500	Duct Housing with Addressable/Analog Sensor Base
9181	B501	Addressable/Analog Sensor Base
9189	B210LP	Addressable/Analog Sensor Base, Low profile
9296	B224RB	Relay Base, Low profile
9297	B524RB	Relay Base
9298	B224BI	Isolator Base, Low profile
9299	B524BI	Isolator Base

Accessory Modules

Faraday Cat. No.	System Sensor P/N	Description
9157	M500MB	Zone Monitor Module
9158	M501M	Device Monitor Module
9159	M500CH	Control Module
9160	M500X	Isolator Module
9180	RA400Z	Remote LED Annunciator
9191	M502M	Interface Module

COMPATIBLE DEVICES FOR INITIATING CIRCUITS

Manual Stations

Faraday Cat. No.	Mfg. P/N
	Faraday
F1GT	17-450334-35
F1GGT	17-450334-38
F1GHT	17-450334-37
	Adalet
PM3823	XHFA-N4
	R.S.G. Inc.
PM6700	RMS-1P-KL
PM6608	RMS-1T-KL
PM6696	RMS-2T-LP-KL
PM6695	RMS-1T-PS-KL
PM6697	RMS-2T-KO-KL
PM6699	RMS-2T-WP-KL
PM6767	RMS-EX-WP-KL

Notes:

Any UL Listed contact type non-coded station with compatible contact ratings is acceptable. The above are listed here for your convenience.

For specific wiring and installation information, read the instructions provided with each device.

Waterflow Switches

Faraday Cat. No.	Mfg. P/N
	System Sensor
PM6615	WFD20
PM6616	WFD25
PM6617	WFD30
PM6618	WFD35
PM6619	WFD40
PM6620	WFD50
PM6621	WFD60
PM6622	WFD80
PM6779	EPS10-1
PM6780	EPS10-2

Notes:

1. Any UL Listed contact type waterflow switch with compatible contact ratings is acceptable. The above are listed here for your convenience.
2. For specific wiring and installation information, read the instructions provided with each device.

Supervisory Switches

Faraday Cat. No.	Mfg. P/N
	System Sensor
PM6623	OSY2
PM6624	PIBV2
PM6781	EPS40-1
PM6782	EPS40-2

Notes:

1. Any UL Listed contact type supervisory switch with compatible contact ratings is acceptable. The above are listed here for your convenience.
2. For specific wiring and installation information, read the instructions provided with each device.

Contact Type Heat Detectors

Faraday Cat. No.	Mfg. Part Number
	Chemtronics
9341	601
9342	602
9343	603
9344	604
9345	621
9346	622
9347	623
9348	624
9300-136	A-135
9300-190	A-200
9301-136	AT-135
9301-190	AT-200
PM2872-136	EPB501
PM2872-190	EPB502
PM2872-136F	EPB503
PM2872-190F	EPB504

Notes:

1. Any UL Listed contact type heat detector with compatible contact ratings is acceptable. The above are listed here for your convenience.
2. For specific wiring and installation information, read the instructions provided with each device.

UL Compatible Four-Wire (Separately Powered) Smoke Detectors

Faraday Detector w/Base	Mfg. Detector w/Base	Maximum Standby Current	Maximum Alarm Current	Notes
Air Products & Controls				
9269	RW-DC-N	0.081m	115mA	Must use EOL Relay
9270	RW-DC-P	0.110m	115mA	Must use EOL Relay
Apollo Fire Detectors				
9260 w/9266	55000-350 w/45681-227	0.130m	100mA	Must use EOL Relay
9261 w/9266	55000-250 w/45681-227	0.081m	100mA	Must use EOL Relay
9264 w/9266	55000-153 w/45681-227	0.086m	100mA	Must use EOL Relay
9274 w/9266	55000-152 w/45681-227	0.096m	100mA	Must use EOL Relay
9259 w/9266	55000-150 w/45681-227	0.086m	100mA	Must use EOL Relay
9221 w/9266	55000-151 w/45681-227	0.086m	100mA	Must use EOL Relay
9222 w/9266	55000-380 w/45681-227	0.205m	100mA	Must use EOL Relay
System Sensor				
9337	1112/24	0.050mA	25mA	Must use EOL Relay
9338	2112/24	0.050mA	25mA	Must use EOL Relay
9339	2112/24T	0.050mA	25mA	Must use EOL Relay
9340	2112/24TSRB	15mA	45mA	Must use EOL Relay
9358 w/9362	1451 w/B402B	0.120mA	36mA	Must use EOL Relay
9359 w/9362	2451 w/B402B	0.120mA	36mA	Must use EOL Relay
9360 w/9362	2451TH w/B402B	0.120mA	36mA	Must use EOL Relay
9447 w/9362	5451 w/B402B	0.120mA	36mA	Must use EOL Relay
9421 w/9362	4451HT w/B402B	0.120mA	36mA	Must use EOL Relay
9183 w/9186	2151 w/B112LP	0.120mA	36mA	Must use EOL Relay
9184 w/9186	1151 w/B112LP	0.120mA	36mA	Must use EOL Relay

Notes:

1. For specific wiring and installation information, read the instructions provided with each device.
2. Each 9273 EOL Relay requires 15 mA. standby current.

DEVICES FOR NOTIFICATION APPLIANCE CIRCUITS

Compatible Notification Appliances

Faraday Catalog Number	Description	Audible Voltage (Volts)	Audible Current (Amps)	Strobe Voltage (Volts)	Strobe Current (Amps)
446(*1)	Bell - Vibrating	21-30 DC	0.110		
476(*1)	Bell - Vibrating	21-30 DC	0.070		
477(*1)	Bell - Single Stroke	21-30 DC	0.360		
2700-E	Strobe Light			20-31 DC	0.059
2700-G	Strobe Light			20-31 DC	0.089
2700-J	Strobe Light			20-31 DC	0.155
2700-K	Strobe Light			20-31 DC	0.164
2700-L	Strobe Light			20-31 DC	0.249
2700-M(*2)	Sync Strobe Light			20-31 DC	0.059
2700-R(*2)	Sync Strobe Light			20-31 DC	0.088
2700-T(*2)	Sync Strobe Light			20-31 DC	0.154
2700-Y(*2)	Sync Strobe Light			20-31 DC	0.170
2700-Z(*2)	Sync Strobe Light			20-31 DC	0.249
2701-E	Strobe Light			20-31 DC	0.059
2701-G	Strobe Light			20-31 DC	0.089
2701-J	Strobe Light			20-31 DC	0.155
2701-K	Strobe Light			20-31 DC	0.164
2701-L	Strobe Light			20-31 DC	0.249
2701-M(*2)	Sync Strobe Light			20-31 DC	0.059
2701-R(*2)	Sync Strobe Light			20-31 DC	0.088
2701-T(*2)	Sync Strobe Light			20-31 DC	0.154
2701-Y(*2)	Sync Strobe Light			20-31 DC	0.170
2701-Z(*2)	Sync Strobe Light			20-31 DC	0.249
2705-E	Strobe Light			20-31 DC	0.059
2705-L	Strobe Light			20-31 DC	0.249
2705-M(*2)	Sync Strobe Light			20-31 DC	0.059
2705-Z(*2)	Sync Strobe Light			20-31 DC	0.249
2820(*2)	Sync Electronic Horn	20-31 DC	0.030		
2821(*2)	Sync Electronic Horn	20-31 DC	0.030		
2824-M(*3)	Sync Electronic Horn w/Sync Strobe	20-31 DC	0.030	20-31 DC	0.059
2824-R(*3)	Sync Electronic Horn w/Sync Strobe	20-31 DC	0.030	20-31 DC	0.088
2824-T(*3)	Sync Electronic Horn w/Sync Strobe	20-31 DC	0.030	20-31 DC	0.154
2824-Y(*3)	Sync Electronic Horn w/Sync Strobe	20-31 DC	0.030	20-31 DC	0.170
2824-Z(*3)	Sync Electronic Horn w/Sync Strobe	20-31 DC	0.030	20-31 DC	0.249
2880	Electronic Signal-8T	20-31 DC	.024-.050 (*4)		
2881	Electronic Signal-8T	20-31 DC	.024-.050 (*4)		
2884-E	Electronic Signal-8T w/Strobe	20-31 DC	.024-.050 (*4)	20-31 DC	0.059
2884-G	Electronic Signal-8T w/Strobe	20-31 DC	.024-.050 (*4)	20-31 DC	0.089
2884-J	Electronic Signal-8T w/Strobe	20-31 DC	.024-.050 (*4)	20-31 DC	0.155
2884-K	Electronic Signal-8T w/Strobe	20-31 DC	.024-.050 (*4)	20-31 DC	0.164
2884-L	Electronic Signal-8T w/Strobe	20-31 DC	.024-.050 (*4)	20-31 DC	0.249
2884- M(*2)	Electronic Signal-8T w/Sync Strobe	20-31 DC	.024-.050 (*4)	20-31 DC	0.059
2884-R(*2)	Electronic Signal-8T w/Sync Strobe	20-31 DC	.024-.050 (*4)	20-31 DC	0.088
2884-T(*2)	Electronic Signal-8T w/Sync Strobe	20-31 DC	.024-.050 (*4)	20-31 DC	0.154
2884-Y(*2)	Electronic Signal-8T w/Sync Strobe	20-31 DC	.024-.050 (*4)	20-31 DC	0.170
2884-Z(*2)	Electronic Signal-8T w/Sync Strobe	20-31 DC	.024-.050 (*4)	20-31 DC	0.249
5330	Electronic Horn-3T	21-32 DC	.020-.025 (*4)		
5333	Electronic Horn-3T	21-32 DC	.020-.025 (*4)		
5334	Electronic Horn-3T	21-32 DC	.020-.025 (*4)		

Faraday Catalog Number	Description	Audible Voltage (Volts)	Audible Current (Amps)	Strobe Voltage (Volts)	Strobe Current (Amps)
5335	Electronic Horn-3T	21-32 DC	.020-.025 (*4)		
5336-(0,X)	Electronic Horn-3T w/Strobe	21-32 DC	.020-.025 (*4)	21-30 DC	0.038
5336-(A,B)(*2)	Electronic Horn-3T w/Sync Strobe	21-32 DC	.020-.025 (*4)	20-31 DC	0.145
5336-(H,U)	Electronic Horn-3T w/Strobe	21-32 DC	.020-.025 (*4)	21-30 DC	0.075
5336-(N,W)	Electronic Horn-3T w/Strobe	21-32 DC	.020-.025 (*4)	21-32 DC	0.079
5336-C(*2)	Electronic Horn-3T w/Sync Strobe	21-32 DC	.020-.025 (*4)	20-31 DC	0.285
5336-D	Electronic Horn-3T w/Strobe	21-32 DC	.020-.025 (*4)	21-32 DC	0.175
5336-S	Electronic Horn-3T w/Strobe	21-32 DC	.020-.025 (*4)	21-32 DC	0.245
5337-(0,X)	Electronic Horn-3T w/Strobe	21-32 DC	.020-.025 (*4)	21-30 DC	0.038
5337-(A,B)(*2)	Electronic Horn-3T w/Sync Strobe	21-32 DC	.020-.025 (*4)	20-31 DC	0.145
5337-(H,U)	Electronic Horn-3T w/Strobe	21-32 DC	.020-.025 (*4)	21-30 DC	0.075
5337-(N,W)	Electronic Horn-3T w/Strobe	21-32 DC	.020-.025 (*4)	21-32 DC	0.079
5337-C(*2)	Electronic Horn-3T w/Sync Strobe	21-32 DC	.020-.025 (*4)	20-31 DC	0.285
5337-D	Electronic Horn-3T w/Strobe	21-32 DC	.020-.025 (*4)	21-32 DC	0.175
5337-S	Electronic Horn-3T w/Strobe	21-32 DC	.020-.025 (*4)	21-32 DC	0.245
5338-(0,X)	Electronic Horn-3T w/Strobe	21-32 DC	.020-.025 (*4)	21-30 DC	0.038
5338-(A,B)(*2)	Electronic Horn-3T w/Sync Strobe	21-32 DC	.020-.025 (*4)	20-31 DC	0.145
5338-(H,U)	Electronic Horn-3T w/Strobe	21-32 DC	.020-.025 (*4)	21-30 DC	0.075
5338-(N,W)	Electronic Horn-3T w/Strobe	21-32 DC	.020-.025 (*4)	21-32 DC	0.079
5340	Electronic Horn	21-32 DC	0.020		
5343	Electronic Horn	21-32 DC	0.020		
5344	Electronic Horn	21-32 DC	0.020		
5345	Electronic Horn	21-32 DC	0.020		
5346-(0,X)	Electronic Horn w/Strobe	21-32 DC	0.020	21-30 DC	0.038
5346-(A,B)(*2)	Electronic Horn w/Sync Strobe	21-32 DC	0.020	20-31 DC	0.145
5346-(H,U)	Electronic Horn w/Strobe	21-32 DC	0.020	21-30 DC	0.075
5346-(N,W)	Electronic Horn w/Strobe	21-32 DC	0.020	21-32 DC	0.079
5346-C(*2)	Electronic Horn w/Sync Strobe	21-32 DC	0.020	20-31 DC	0.285
5346-D	Electronic Horn w/Strobe	21-32 DC	0.020	21-32 DC	0.175
5346-S	Electronic Horn w/Strobe	21-32 DC	0.020	21-32 DC	0.245
5350	Electronic Horn-3T	21-32 DC	.020-.025 (*4)		
5353	Electronic Horn-3T	21-32 DC	.020-.025 (*4)		
5354	Electronic Horn-3T	21-32 DC	.020-.025 (*4)		
5355	Electronic Horn-3T	21-32 DC	.020-.025 (*4)		
5360	Electronic Horn	21-32 DC	0.020		
5363	Electronic Horn	21-32 DC	0.020		
5364	Electronic Horn	21-32 DC	0.020		
5365	Electronic Horn	21-32 DC	0.020		
5370	Electronic Horn-8T	12-32 DC	.020-.050 (*4)		
5373	Electronic Signal-8T	12-32 DC	.020-.050 (*4)		
5374	Electronic Signal-8T	12-32 DC	.020-.050 (*4)		
5375	Electronic Signal-8T	12-32 DC	.020-.050 (*4)		
5376-(A,B)(*2)	Electronic Signal-8T w/Sync Strobe	12-32 DC	.020-.050 (*4)	20-31 DC	0.145
5376-(N,W)	Electronic Signal-8T w/Strobe	12-32 DC	.020-.050 (*4)	21-32 DC	0.079
5376-C(*2)	Electronic Signal-8T w/Sync Strobe	12-32 DC	.020-.050 (*4)	20-31 DC	0.285
5376-D	Electronic Signal-8T w/Strobe	12-32 DC	.020-.050 (*4)	21-32 DC	0.175
5376-S	Electronic Signal-8T w/Strobe	12-32 DC	.020-.050 (*4)	21-32 DC	0.245
5377-(A,B)(*2)	Electronic Signal-8T w/Sync Strobe	12-32 DC	.020-.050 (*4)	20-31 DC	0.145
5377-(N,W)	Electronic Signal-8T w/Strobe	12-32 DC	.020-.050 (*4)	21-32 DC	0.079
5377-C(*2)	Electronic Signal-8T w/Sync Strobe	12-32 DC	.020-.050 (*4)	20-31 DC	0.285
5377-D	Electronic Signal-8T w/Strobe	12-32 DC	.020-.050 (*4)	21-32 DC	0.175
5377-S	Electronic Signal-8T w/Strobe	12-32 DC	.020-.050 (*4)	21-32 DC	0.245
5378-(A,B)(*2)	Electronic Signal-8T w/Sync Strobe	12-32 DC	.020-.050 (*4)	20-31 DC	0.145
5378-(N,W)	Electronic Signal-8T w/Strobe	12-32 DC	.020-.050 (*4)	21-32 DC	0.079

Faraday Catalog Number	Description	Audible Voltage (Volts)	Audible Current (Amps)	Strobe Voltage (Volts)	Strobe Current (Amps)
5380	Electronic Horn-8T	12-32 DC	.020-.050 (*4)		
5383	Electronic Signal-8T	12-32 DC	.020-.050 (*4)		
5384	Electronic Signal-8T	12-32 DC	.020-.050 (*4)		
5385	Electronic Signal-8T	12-32 DC	.020-.050 (*4)		
5386-(A,B)(*2)	Electronic Signal-8T w/Sync Strobe	12-32 DC	.020-.050 (*4)	20-31 DC	0.145
5386-(N,W)	Electronic Signal-8T w/Strobe	12-32 DC	.020-.050 (*4)	21-32 DC	0.079
5386-C(*2)	Electronic Signal-8T w/Sync Strobe	12-32 DC	.020-.050 (*4)	20-31 DC	0.285
5386-D	Electronic Signal-8T w/Strobe	12-32 DC	.020-.050 (*4)	21-32 DC	0.175
5386-S	Electronic Signal-8T w/Strobe	12-32 DC	.020-.050 (*4)	21-32 DC	0.245
5387-(A,B)(*2)	Electronic Signal-8T w/Sync Strobe	12-32 DC	.020-.050 (*4)	20-31 DC	0.145
5387-(N,W)	Electronic Signal-8T w/Strobe	12-32 DC	.020-.050 (*4)	21-32 DC	0.079
5387-C(*2)	Electronic Signal-8T w/Sync Strobe	12-32 DC	.020-.050 (*4)	20-31 DC	0.285
5387-D	Electronic Signal-8T w/Strobe	12-32 DC	.020-.050 (*4)	21-32 DC	0.175
5387-S	Electronic Signal-8T w/Strobe	12-32 DC	.020-.050 (*4)	21-32 DC	0.245
5388-(A,B)(*2)	Electronic Signal-8T w/Sync Strobe	12-32 DC	.020-.050 (*4)	20-31 DC	0.145
5388-(N,W)	Electronic Signal-8T w/Strobe	12-32 DC	.020-.050 (*4)	21-32 DC	0.079
5405	Sync Control Unit	20-31 DC	0.020		
5406	Sync Control Unit	20-31 DC	0.020		
5508-(0,X)	Strobe Light			21-30 DC	0.038
5508-(A,B)(*2)	Sync Strobe Light			20-31 DC	0.145
5508-(H,U)	Strobe Light			21-30 DC	0.075
5508-(N,W)	Strobe Light			21-32 DC	0.079
5508-C(*2)	Sync Strobe Light			20-31 DC	0.285
5508-D	Strobe Light			21-32 DC	0.175
5508-S	Strobe Light			21-32 DC	0.245
5509-(0,X)	Strobe Light			21-30 DC	0.038
5509-(H,U)	Strobe Light			21-30 DC	0.075
5510-(0,X)	Strobe Light			21-30 DC	0.038
5510-(A,B)(*2)	Sync Strobe Light			20-31 DC	0.145
5510-(N,W)	Strobe Light			21-32 DC	0.079
5511-(0,X)	Strobe Light			21-30 DC	0.038
5511-(A,B)(*2)	Sync Strobe Light			20-31 DC	0.145
5511-(H,U)	Strobe Light			21-30 DC	0.075
5511-(N,W)	Strobe Light			21-32 DC	0.079
5511-C(*2)	Sync Strobe Light			20-31 DC	0.285
5511-D	Strobe Light			21-32 DC	0.175
5511-S	Strobe Light			21-32 DC	0.245
5512-(0,X)	Strobe Light			21-30 DC	0.038
5512-(A,B)(*2)	Sync Strobe Light			20-31 DC	0.145
5512-(H,U)	Strobe Light			21-30 DC	0.075
5512-(N,W)	Strobe Light			21-32 DC	0.079
5512-C(*2)	Sync Strobe Light			20-31 DC	0.285
5512-D	Strobe Light			21-32 DC	0.175
5512-S	Strobe Light			21-32 DC	0.245
5516-(0,X)	Strobe Light			21-30 DC	0.038
5516-(A,B)	Sync Strobe Light			20-31 DC	0.145
5516-(H,U)	Strobe Light			21-30 DC	0.075
5516-(N,W)	Strobe Light			21-32 DC	0.079
5516-C(*2)	Sync Strobe Light			20-31 DC	0.285
5516-D	Strobe Light			21-32 DC	0.175
5516-S	Strobe Light			21-32 DC	0.245
5517-(0,X)	Strobe Light			21-30 DC	0.038
5517-(A,B)(*2)	Sync Strobe Light			20-31 DC	0.145
5517-(H,U)	Strobe Light			21-30 DC	0.075

Faraday Catalog Number	Description	Audible Voltage (Volts)	Audible Current (Amps)	Strobe Voltage (Volts)	Strobe Current (Amps)
5517-(N,W)	Strobe Light			21-32 DC	0.079
5517-C(*2)	Sync Strobe Light			20-31 DC	0.285
5517-D	Strobe Light			21-32 DC	0.175
5517-S	Strobe Light			21-32 DC	0.245
5518-(0,X)	Strobe Light			21-30 DC	0.038
5518-(A,B)(*2)	Sync Strobe Light			20-31 DC	0.145
5518-(H,U)	Strobe Light			21-30 DC	0.075
5518-(N,W)	Strobe Light			21-32 DC	0.079
5519-(A,B)(*2)	Sync Strobe Light			20-31 DC	0.145
5519-(N,W)	Strobe Light			21-32 DC	0.079
5519-C(*2)	Sync Strobe Light			20-31 DC	0.285
5519-D	Strobe Light			21-32 DC	0.175
5519-S	Strobe Light			21-32 DC	0.245
5521-(0,X)	Strobe Light			21-30 DC	0.038
5521-(A,B)(*2)	Sync Strobe Light			20-31 DC	0.145
5521-(H,U)	Strobe Light			21-30 DC	0.075
5521-(N,W)	Strobe Light			21-32 DC	0.079
5521-C(*2)	Sync Strobe Light			20-31 DC	0.285
5521-D	Strobe Light			21-32 DC	0.175
5521-S	Strobe Light			21-32 DC	0.245
5521C-(A,B)(*2)	Sync Strobe Light			20-31 DC	0.145
5521C-(N,W)	Strobe Light			21-32 DC	0.079
5521C-C(*2)	Sync Strobe Light			20-31 DC	0.285
5521C-(N,W)	Strobe Light			21-32 DC	0.079
5522C-D	Strobe Light			21-32 DC	0.175
5521C-S	Strobe Light			21-32 DC	0.245
5522-(0,X)	Strobe Light			21-30 DC	0.038
5522-(A,B)(*2)	Sync Strobe Light			20-31 DC	0.145
5522-(H,U)	Strobe Light			21-30 DC	0.075
5522-(N,W)	Strobe Light			21-32 DC	0.079
5522-C(*2)	Sync Strobe Light			20-31 DC	0.285
5522-D	Strobe Light			21-32 DC	0.175
5522-S	Strobe Light			21-32 DC	0.245
5522C-(A,B)(*2)	Sync Strobe Light			20-31 DC	0.145
5522C-(N,W)	Strobe Light			21-32 DC	0.079
5522C-C(*2)	Sync Strobe Light			20-31 DC	0.285
5522C-(N,W)	Strobe Light			21-32 DC	0.079
5522C-D	Strobe Light			21-32 DC	0.175
5522C-S	Strobe Light			21-32 DC	0.245
6120	Horn	21-30 DC	0.035		
6140	Horn	21-30 DC	0.065		
6220	Horn	21-30 DC	0.038		
6223	Horn	21-30 DC	0.038		
6224	Horn	21-30 DC	0.038		
6225	Horn	21-30 DC	0.038		
6226-(A,B)(*2)	Horn w/Sync Strobe	21-30 DC	0.038	20-31 DC	0.145
6226-(N,W)	Horn w/Strobe	21-30 DC	0.038	21-32 DC	0.079
6226-C(*2)	Horn w/Sync Strobe	21-30 DC	0.038	20-31 DC	0.285
6226-D	Horn w/Strobe	21-30 DC	0.038	21-32 DC	0.175
6226-S	Horn w/Strobe	21-30 DC	0.038	21-32 DC	0.245
6227-(A,B)(*2)	Horn w/Sync Strobe	21-30 DC	0.038	20-31 DC	0.145
6227-(N,W)	Horn w/Strobe	21-30 DC	0.038	21-32 DC	0.079
6227-C(*2)	Horn w/Sync Strobe	21-30 DC	0.038	20-31 DC	0.285
6227-D	Horn w/Strobe	21-30 DC	0.038	21-32 DC	0.175

Faraday Catalog Number	Description	Audible Voltage (Volts)	Audible Current (Amps)	Strobe Voltage (Volts)	Strobe Current (Amps)
6227-S	Horn w/Strobe	21-30 DC	0.038	21-32 DC	0.245
6228-(A,B)(*2)	Horn w/Sync Strobe	21-30 DC	0.038	20-31 DC	0.145
6228-(N,W)	Horn w/Strobe	21-30 DC	0.038	21-32 DC	0.079
6230	Horn	21-30 DC	0.038		
6234-E	Horn w/Strobe	21-30 DC	0.038	20-31 DC	0.059
6234-G	Horn w/Strobe	21-30 DC	0.038	20-31 DC	0.089
6234-J	Horn w/Strobe	21-30 DC	0.038	20-31 DC	0.155
6234-K	Horn w/Strobe	21-30 DC	0.038	20-31 DC	0.164
6234-L	Horn w/Strobe	21-30 DC	0.038	20-31 DC	0.249
6234-M(*2)	Horn w/Sync Strobe	21-30 DC	0.038	20-31 DC	0.059
6234-R(*2)	Horn w/Sync Strobe	21-30 DC	0.038	20-31 DC	0.088
6234-T(*2)	Horn w/Sync Strobe	21-30 DC	0.038	20-31 DC	0.155
6234-Y(*2)	Horn w/Sync Strobe	21-30 DC	0.038	20-31 DC	0.170
6234-Z(*2)	Horn w/Sync Strobe	21-30 DC	0.038	20-31 DC	0.249
6235-E	Horn w/Strobe-WP	21-30 DC	0.038	20-31 DC	0.059
6235-L	Horn w/Strobe-WP	21-30 DC	0.038	20-31 DC	0.249
6235-M(*2)	Horn w/Sync Strobe-WP	21-30 DC	0.038	20-31 DC	0.059
6235-Z(*2)	Horn w/Sync Strobe-WP	21-30 DC	0.038	20-31 DC	0.249
6238-E	Horn w/Strobe	21-30 DC	0.038	20-31 DC	0.059
6238-G	Horn w/Strobe	21-30 DC	0.038	20-31 DC	0.089
6238-J	Horn w/Strobe	21-30 DC	0.038	20-31 DC	0.155
6238-K	Horn w/Strobe	21-30 DC	0.038	20-31 DC	0.164
6238-L	Horn w/Strobe	21-30 DC	0.038	20-31 DC	0.249
6238-M(*2)	Horn w/Sync Strobe	21-30 DC	0.038	20-31 DC	0.059
6238-R(*2)	Horn w/Sync Strobe	21-30 DC	0.038	20-31 DC	0.088
6238-T(*2)	Horn w/Sync Strobe	21-30 DC	0.038	20-31 DC	0.155
6238-Y(*2)	Horn w/Sync Strobe	21-30 DC	0.038	20-31 DC	0.170
6238-Z(*2)	Horn w/Sync Strobe	21-30 DC	0.038	20-31 DC	0.249
6240	Horn	21-30 DC	0.065		
6243	Horn	21-30 DC	0.065		
6244	Horn	21-30 DC	0.065		
6245	Horn	21-30 DC	0.065		
6246-(A,B)(*2)	Horn w/Sync Strobe	21-30 DC	0.065	20-31 DC	0.145
6246-(N,W)	Horn w/Strobe	21-30 DC	0.065	21-32 DC	0.079
6246-C(*2)	Horn w/Sync Strobe	21-30 DC	0.065	20-31 DC	0.285
6246-D	Horn w/Strobe	21-30 DC	0.065	21-32 DC	0.175
6246-S	Horn w/Strobe	21-30 DC	0.065	21-32 DC	0.245
6247-(A,B)(*2)	Horn w/Sync Strobe	21-30 DC	0.065	20-31 DC	0.145
6247-(N,W)	Horn w/Strobe	21-30 DC	0.065	21-32 DC	0.079
6247-C(*2)	Horn w/Sync Strobe	21-30 DC	0.065	20-31 DC	0.285
6247-D	Horn w/Strobe	21-30 DC	0.065	21-32 DC	0.175
6247-S	Horn w/Strobe	21-30 DC	0.065	21-32 DC	0.245
6248-(A,B)(*2)	Horn w/Sync Strobe	21-30 DC	0.065	20-31 DC	0.145
6248-(N,W)	Horn w/Strobe	21-30 DC	0.065	21-32 DC	0.079
6250	Horn	21-30 DC	0.065		
6254-E	Horn w/Strobe	21-30 DC	0.065	20-31 DC	0.059
6254-G	Horn w/Strobe	21-30 DC	0.065	20-31 DC	0.089
6254-J	Horn w/Strobe	21-30 DC	0.065	20-31 DC	0.155
6254-K	Horn w/Strobe	21-30 DC	0.065	20-31 DC	0.164
6254-L	Horn w/Strobe	21-30 DC	0.065	20-31 DC	0.249
6254-M(*2)	Horn w/Sync Strobe	21-30 DC	0.065	20-31 DC	0.059
6254-R(*2)	Horn w/Sync Strobe	21-30 DC	0.065	20-31 DC	0.088
6254-T(*2)	Horn w/Sync Strobe	21-30 DC	0.065	20-31 DC	0.155
6254-Y(*2)	Horn w/Sync Strobe	21-30 DC	0.065	20-31 DC	0.170

Faraday Catalog Number	Description	Audible Voltage (Volts)	Audible Current (Amps)	Strobe Voltage (Volts)	Strobe Current (Amps)
6254-Z(*2)	Horn w/Sync Strobe	21-30 DC	0.065	20-31 DC	0.249
6255-E	Horn w/Strobe-WP	21-30 DC	0.065	20-31 DC	0.059
6255-L	Horn w/Strobe-WP	21-30 DC	0.065	20-31 DC	0.249
6255-M(*2)	Horn w/Sync Strobe-WP	21-30 DC	0.065	20-31 DC	0.059
6255-Z(*2)	Horn w/Sync Strobe-WP	21-30 DC	0.065	20-31 DC	0.249
6258-E	Horn w/Strobe	21-30 DC	0.065	20-31 DC	0.059
6258-G	Horn w/Strobe	21-30 DC	0.065	20-31 DC	0.089
6258-J	Horn w/Strobe	21-30 DC	0.065	20-31 DC	0.155
6258-K	Horn w/Strobe	21-30 DC	0.065	20-31 DC	0.164
6258-L	Horn w/Strobe	21-30 DC	0.065	20-31 DC	0.249
6258-M(*2)	Horn w/Sync Strobe	21-30 DC	0.065	20-31 DC	0.059
6258-R(*2)	Horn w/Sync Strobe	21-30 DC	0.065	20-31 DC	0.088
6258-T(*2)	Horn w/Sync Strobe	21-30 DC	0.065	20-31 DC	0.155
6258-Y(*2)	Horn w/Sync Strobe	21-30 DC	0.065	20-31 DC	0.170
6258-Z(*2)	Horn w/Sync Strobe	21-30 DC	0.065	20-31 DC	0.249
6300	Mini-Horn	20-31 DC	0.025		
6301	Mini-Horn	20-31 DC	0.025		
6302-(A,B)(*2)	Mini-Horn w/Sync Strobe	20-31 DC	0.025	20-31 DC	0.145
6302-(N,W)	Mini-Horn w/Strobe	20-31 DC	0.025	21-32 DC	0.079
6302-C(*2)	Mini-Horn w/Sync Strobe	20-31 DC	0.025	20-31 DC	0.285
6302-D	Mini-Horn w/Strobe	20-31 DC	0.025	21-32 DC	0.175
6302-S	Mini-Horn w/Strobe	20-31 DC	0.025	21-32 DC	0.245
6304-E	Mini-Horn w/Strobe	20-31 DC	0.025	20-31 DC	0.059
6304-G	Mini-Horn w/Strobe	20-31 DC	0.025	20-31 DC	0.089
6304-J	Mini-Horn w/Strobe	20-31 DC	0.025	20-31 DC	0.155
6304-K	Mini-Horn w/Strobe	20-31 DC	0.025	20-31 DC	0.164
6304-L	Mini-Horn w/Strobe	20-31 DC	0.025	20-31 DC	0.249
6304-M(*2)	Mini-Horn w/Sync Strobe	20-31 DC	0.025	20-31 DC	0.059
6304-R(*2)	Mini-Horn w/Sync Strobe	20-31 DC	0.025	20-31 DC	0.088
6304-T(*2)	Mini-Horn w/Sync Strobe	20-31 DC	0.025	20-31 DC	0.154
6304-Y(*2)	Mini-Horn w/Sync Strobe	20-31 DC	0.025	20-31 DC	0.170
6304-Z(*2)	Mini-Horn w/Sync Strobe	20-31 DC	0.025	20-31 DC	0.249
6310	Mini-Horn-S/T	20-31 DC	0.025		
6311	Mini-Horn-S/T	20-31 DC	0.025		
6312-(A,B)(*2)	Mini-Horn-S/T w/Sync Strobe	20-31 DC	0.025	20-31 DC	0.145
6312-(N,W)	Mini-Horn-S/T w/Strobe	20-31 DC	0.025	21-32 DC	0.079
6312-C(*2)	Mini-Horn-S/T w/Sync Strobe	20-31 DC	0.025	20-31 DC	0.285
6312-D	Mini-Horn-S/T w/Strobe	20-31 DC	0.025	21-32 DC	0.175
6312-S	Mini-Horn-S/T w/Strobe	20-31 DC	0.025	21-32 DC	0.245
6314-E	Mini-Horn-S/T w/Strobe	20-31 DC	0.025	20-31 DC	0.059
6314-G	Mini-Horn-S/T w/Strobe	20-31 DC	0.025	20-31 DC	0.089
6314-J	Mini-Horn-S/T w/Strobe	20-31 DC	0.025	20-31 DC	0.155
6314-K	Mini-Horn w/Strobe	20-31 DC	0.025	20-31 DC	0.164
6314-L	Mini-Horn-S/T w/Strobe	20-31 DC	0.025	20-31 DC	0.249
6314-M(*2)	Mini-Horn-S/T w/Sync Strobe	20-31 DC	0.025	20-31 DC	0.059
6314-R(*2)	Mini-Horn-S/T w/Sync Strobe	20-31 DC	0.025	20-31 DC	0.088
6314-T(*2)	Mini-Horn-S/T w/Sync Strobe	20-31 DC	0.025	20-31 DC	0.154
6314-Y(*2)	Mini-Horn-S/T w/Sync Strobe	20-31 DC	0.025	20-31 DC	0.170
6314-Z(*2)	Mini-Horn-S/T w/Sync Strobe	20-31 DC	0.025	20-31 DC	0.249
6320(*2)	Sync Electronic Horn	20-31 DC	0.030		
6321(*2)	Sync Electronic Horn	20-31 DC	0.030		
6322-(A,B)(*3)	Sync Electronic Horn w/Sync Strobe	20-31 DC	0.030	20-31 DC	0.145
6322-C(*3)	Sync Electronic Horn w/Sync Strobe	20-31 DC	0.025	20-31 DC	0.285
6380	Electronic Signal-8T	20-31 DC	.024-.050 (*4)		

Faraday Catalog Number	Description	Audible Voltage (Volts)	Audible Current (Amps)	Strobe Voltage (Volts)	Strobe Current (Amps)
6381	Electronic Signal-8T	20-31 DC	.024-.050 (*4)		
6382-(A,B)(*2)	Electronic Signal-8T w/Sync Strobe	20-31 DC	.024-.050 (*4)	20-31 DC	0.145
6382-(N,W)	Electronic Signal-8T w/Strobe	20-31 DC	.024-.050 (*4)	21-32 DC	0.079
6382-C(*2)	Electronic Signal-8T w/Sync Strobe	20-31 DC	.024-.050 (*4)	20-31 DC	0.285
6382-D	Electronic Signal-8T w/Sync Strobe	20-31 DC	.024-.050 (*4)	21-32 DC	0.175
6382-S	Electronic Signal-8T w/Sync Strobe	20-31 DC	.024-.050 (*4)	21-32 DC	0.245

Key:

- (*1) 1=10" gong, 4=4" gong, 5=chime, 6=6" gong, 8=8" gong
- (*2) Sync Strobe Light or Sync Electronic Horn require 5405 Sync Control Module
- (*3) Sync Electronic Horn and Sync Strobe Light require 5405 or 5406 Sync Control Module
- (*4) See Installation Instructions for the current of the desired tone.

- Cat. No. xxxx-0 = Strobe Light (UL1638 4.5cd)
- Cat. No. xxxx-H = Strobe Light (UL1638 15cd)
- Cat. No. xxxx-X = Strobe Light (UL1638 30cd)
- Cat. No. xxxx-U = Strobe Light (UL1638 120cd)
- Cat. No. xxxx-N = Strobe Light (UL1971 15cd)
- Cat. No. xxxx-W = Strobe Light (UL1971 15/75cd)
- Cat. No. xxxx-D = Strobe Light (UL1971 75cd)
- Cat. No. xxxx-S = Strobe Light (UL1971 110cd)
- Cat. No. xxxx-A = Sync Strobe Light (UL1971 15cd)
- Cat. No. xxxx-B = Sync Strobe Light (UL1971 15/75cd)
- Cat. No. xxxx-C = Sync Strobe Light (UL1971 75cd)
- Cat. No. xxxx-E = Strobe Light (UL1971 15/75cd)
- Cat. No. xxxx-G = Strobe Light (UL1971 30/75cd)
- Cat. No. xxxx-J = Strobe Light (UL1971 60/75cd)
- Cat. No. xxxx-K = Strobe Light (UL1971 75cd)
- Cat. No. xxxx-L = Strobe Light (UL1971 110cd)
- Cat. No. xxxx-M = Sync Strobe Light (UL1971 15/75cd)
- Cat. No. xxxx-R = Sync Strobe Light (UL1971 30/75cd)
- Cat. No. xxxx-T = Sync Strobe Light (UL1971 60/75cd)
- Cat. No. xxxx-Y = Sync Strobe Light (UL1971 75cd)
- Cat. No. xxxx-Z = Sync Strobe Light (UL1971 110cd)

COMPATIBLE ACCESSORY DEVICES

Faraday Cat. No.	Mfg. Part Number	Description
	Faraday	
R711-1	711-1	Polarized Auxiliary Relay
MEP-100	15050	Mini-Evac Control Unit
RSE-100	15070	Remote Signal Expander
15222A	15222A	Signal Expander Panel
MVP-500	15060	Mini-Voice Control Unit
MVP-501	15061	Mini-Voice Control Unit

Notes:

1. The accessory devices listed above may be wired to activate from the notification appliance circuits.
2. For specific wiring and installation information, read the instructions provided with each device.

DEVICES FOR AUXILIARY POWER OUTPUTS

The following lists compatible devices for the auxiliary power outputs.

- Door Holders
- Relays

Four Wire (Separately Powered) Heat & Smoke Detectors, See Devices for Initiating Device Circuits.

Door Holders

Not applicable at this time.

Relays

Faraday Cat. No.	Mfg. Part Number	Description
	Faraday LLC	
R711-1	711-1	Remote Relay Unit
	Air Products & Controls	
R712-1	MR-101/C	Remote Relay Unit
R712-2	MR-201/C	Remote Relay Unit
R712-4	MR-104/C	Remote Relay Unit
R712-8	MR-204/C	Remote Relay Unit
9273	PAM-4	E.O.L. Relay
	System Sensor	
PM6849	A77-716B	E.O.L. Relay

Notes:

1. The accessory devices listed above may be wired to the auxiliary power outputs.
2. For specific wiring and installation information, read the instructions provided with each device.

X. APPENDIX-C: TROUBLESHOOTING

DEFINITIONS FOR EVENT HISTORY ENTRIES

A. General

ENTRY	INDICATES
ALARM	General alarm
ALRM	Alarm
AVCntr	Alarm Verify counter
Blank	Plain alarm
CrossZone	cross zone point
CZ1A	Cross zone
CZ1B	Cross zone
CZ2A	Cross zone
CZ2B	Cross zone
DETECTOR	General alarm
HEAT	Thermal sensor
ION	Ion sensor
LCDxx	LCD Annunciator xx
MAIN	Main panel
MANL PULL	Manual pull station
Mntc	Sensor maintenance alert
PAS	Positive alarm sequence
PAS INHBT	PAS inhibit switch
PHOTO	PE sensor
PRE SIGNL	pre-signal
PreA	Pre-alarm
SUPERVSRV	Supervisory
SUPR	Supervisory
TRBL	Trouble
TROUBLE	Trouble
USER1	User-defined input 1
USER2	User-defined input 2
USER3	User-defined input 3
USER4	User-defined input 4
WATERFLOW	Waterflow

B. System Troubles

ENTRY	INDICATES
AC Trouble	AC input low or off
AddrLp I DBLSHT	Double short trouble on addressable loop I
AddrLp I OPEN	Open circuit trouble on addressable loop I
AddrLp I SHORT	Short circuit trouble on addressable loop I
BATT Trouble	Battery input low or off
CMIaa NoRespons	Programmed control module not responding
DACT Trouble	DACT trouble
GRND FAULT Trbl	Ground Fault trouble
LCDxx NoRespons	LCD Annunciator xx programmed but is not responding
LCDxx Not Pgmd	LCD Annunciator xx is not programmed but is responding
LCDxx Trouble	LCD Annunciator xx reports trouble
MDI00 Addr=00	Module on loop I responded to address 00
MDIaa DataError	Data error trouble on module on loop I addr aa
MMIaa NoRespons	Programmed monitor module not responding
NACxx Trouble	NAC xx is open or shorted
Printer Error	Printer is off-line or out of paper
QuickTest Abort	Quick Test Timer expired causing abnormal exit of Quick Test
SNI00 Addr=00	Sensor on loop I responded to address 00
SNIaa DataError	Data error trouble on sensor on loop I address aa
SNIaa NoRespons	Programmed sensor not responding
Trb Reminder	Trouble Reminder timer expired

C. System Events

ENTRY	INDICATES/NOTES
Alarm Silenced	MAIN, LCDxx shown on bottom line
All AV Ctrs Clr	All AV counters cleared
AutoProgram Run	Auto programming function run
Backup Cnfg Check	Backup configuration validated, result on bottom line
Backup Cnfg Edit	Backup configuration edited
CMIaa ActvnCnfd	Non-relay CM activation confirmed by trouble input on
ConfigsCompared	Backup and primary configurations compared, result on bottom line
ConfigsSwapped	Backup and Primary configurations swapped
EventHist Clear	Event History cleared
Mnt Lvl Enter	Entered Maintenance level
Mnt Lvl Exit	Exited Maintenance level
Mnt Lvl PW Changed	Changed Maintenance level password
MMIaa Disabled	MAIN or LCDxx shown on bottom line
MMIaa Enabled	MAIN or LCDxx shown on bottom line
NACxx Active Confirm	NAC activation confirmed
Panel Reset	MAIN, LCDxx shown on bottom line
Power Up	
PriConfigCopied	Primary configuration copied to backup
QuickTest Exit	Exited Quick Test, MAIN or LCDxx shown on bottom line
QuickTest Start	Started Quick Test, MAIN or LCDxx shown on bottom line
SNlaa AV CtrClr	AV counter for sensor SNlaa cleared
SNlaa AV CtrRII	Alarm Verification counter rolled over to 0
SNlaa Disabled	MAIN or LCDxx shown on bottom line
SNlaa Enabled	MAIN or LCDxx shown on bottom line
System Date Changed	Changed system date, old and new dates shown on lines 3 and 4
System Time Changed	Changed system time, old and new times shown on lines 3 and 4
Tech Lvl Enter	Entered Tech level
Tech Lvl Exit	Exited Tech level
Tech Lvl PW Changed	Changed Tech level password
User Lvl Enter	Entered User level
User Lvl Exit	Exited User level

This page is intentionally blank.

XI. APPENDIX-D: INSTALLATION INSTRUCTIONS

This Appendix provides installation instructions for the following option modules and accessories:

- 12103 RS232 Board 447054
- 12105 Serial Digital Communicator 447063
- 12408 Auxiliary Power Supply 446066
- 12506 Remote LCD Annunciator 446983
- 12507 Serial Relay Unit 447073
12508 Serial Relay Extender
- 12509 Serial Annunciator Unit 447074
12510 Serial Annunciator Extender
- 401403 Fire Alarm Accessory Enclosure 447138

This page is intentionally blank.

INSTALLATION INSTRUCTIONS AND WIRING FOR RS232 INTERFACE BOARD CAT. NO. IM232 P/N 12103

The 12103 Interface Board is an optional module for the 12100 Fire Alarm System Control Unit. The Interface Board provides a serial RS232 connection for logging events to a printer, terminal or computer. The Interface Board is mounted on the Main Board.

PARTS SUPPLIED

1	12103	RS232 Interface Board
4	943165	Spacers, 1"
1	18965	Keps Nut, #6-32
1	944139	Cable Assembly
1	447054	Instruction Sheet

12103 MOUNTING

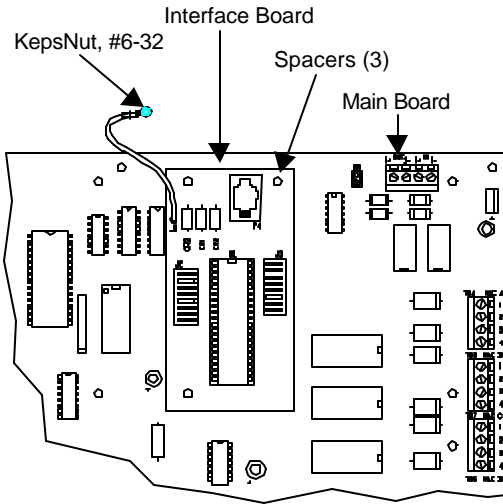

Step 1.) Installation is to be done by qualified personnel who have thoroughly read and understood this instruction sheet.

Step 2.) Disconnect all power into system, including batteries.

Step 3.) Mount RS232 Interface Board as shown, using three spacers (P/N 943165) to the Main Board or using four spacers (P/N 943165) to the City Tie Board (if used).

NOTE: Check to see that the header and connectors are mated properly.

Step 4.) Secure ground wire, using keps nut (P/N 18965).

Step 5.) Plug proper cable assembly into connector P4 as shown below.

Step 6.) Apply power to system.

Step 7.) Check for proper operation of functions.

Note: This connection is limited to be in the same room.

12103 COMPUTER CONNECTION

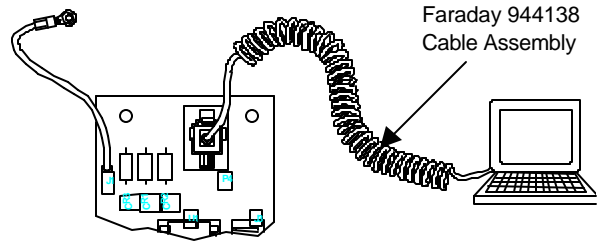

Note: The 944138 Cable Assembly provides a 9-pin female connector. A 9-pin male to 25 pin female adapter may be required for some computers.

12103 PRINTER OR TERMINAL CONNECTION

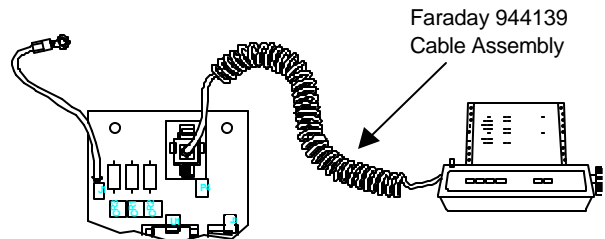

INSTALLATION INSTRUCTIONS AND WIRING FOR DACT BOARD CAT. NO. DC-1K P/N 12105

The 12105 DACT Board is an optional module for the 12100 Fire Alarm System Control Unit. The DACT (Digital Alarm Communicator Transmitter) Board provides telephone line connections for communication with a DACR (Digital Alarm Communicator Receiver). The DACT Board is mounted on the Main Board. The DACT Board options are set through the control unit programming sequence.

PARTS SUPPLIED

1	12105	DACT Board
4	943165	Spacers, 1"
1	18965	Keps Nut, #6-32
1	447063	Instruction Sheet

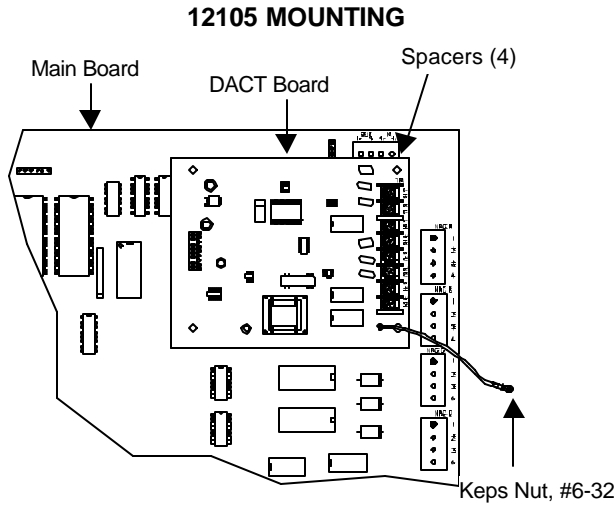

Step 1.) Installation is to be done by qualified personnel who have thoroughly read and understood this instruction sheet.

Step 2.) Disconnect all power into system, including batteries.

Step 3.) Mount DACT Board as shown, using four spacers (P/N 943165) to the Main Board.

NOTE: Check to see that the header and connectors are mated properly.

Step 4.) Attach ground wire as shown, using #6-32 Keps Nut (P/N 18965) to backbox stud.

Step 5.) Attach conduit and run wires as required.

Step 6.) Connect wires to the fire alarm system control unit as required.

Step 7.) Apply power to system.

Step 8.) Program for proper operation of functions.

a) Tech Level>>Outputs>Option Mods>DACT CFG

(Set DACT line and general configurations)

b) Tech Level>>Outputs>Option Mods>DACT ACCTS

(Set DACT account configurations)

c) Maint Level>>Disable/Enable>Outputs>DACT >Enabled

NOTE: See Programmer's Manual (P/N 447064) for more details on programming.

Step 9.) Check for proper operation of functions.

413699 WIRING

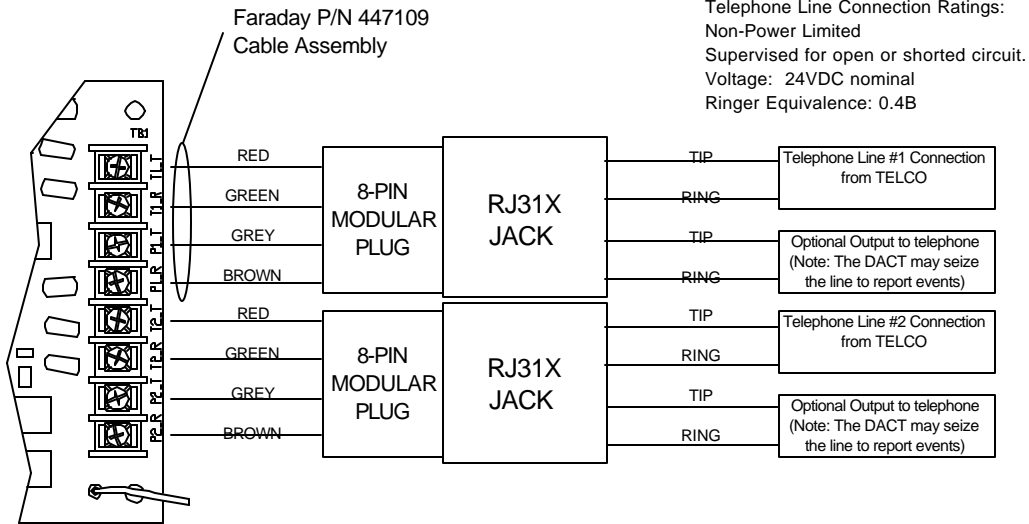

NOTE: The RJ31X provides a convenient connection allowing the DACT to be installed and removed without requiring re-wiring and can be installed by the telephone installer.

413699 FORMAT DESCRIPTION

Format	Description
SIA DCS 8	Security Industry Association - Digital Communications Standard. Format may send up to eight events a call. SIA 1997 Level Ia compatibility with support for O (old) blocks and 300 Baud (FAST) operation. Sends an account number (up to 6 digits), a 2 character code and 3-digit identifier up to four times with FSK frequency encoding.
SIA DCS 20	See SIA DCS 8, except format may send up to twenty events a call.
Ademco Contact ID	Sends a 4-digit account number, a 3-digit code and 3-digit identifier up to four rounds of dual tone multiple frequency with 1400 and 2300 Hz handshake frequency.
3/1 1400HZ	Sends a 3-digit account number and a 1-digit code up to four rounds at 20 pps with 1400 Hz handshake frequency.
3/1 2300HZ	Sends a 3-digit account number and a 1-digit code up to four rounds at 20 pps with 2300 Hz handshake frequency.
4/2 1400HZ	Sends a 4-digit account number and a 2-digit code up to four rounds at 20 pps with 1400 Hz handshake frequency.
4/2 2300HZ	Sends a 4-digit account number and a 2-digit code up to four rounds at 20 pps with 2300 Hz handshake frequency.

COMPATIBLE RECEIVERS/FORMATS

Receiver Manufacturer	Compatible Receivers	SIA DCS 8	SIA DCS 20	Ademco Contact ID	3/1 1400HZ	3/1 2300HZ	4/2 1400HZ	4/2 2300HZ
Osborne-Hoffman, Inc.	QUICKALERT! Model II			Ademco Contact ID	Fast 3+1 1400HZ	Fast 3+1 2300HZ	Fast 4+2 1400HZ	Fast 4+2 2300HZ
Osborne-Hoffman, Inc.	OH2000	SIA 1	SIA 1	Ademco Contact ID	Fast 3+1 1400HZ	Fast 3+1 2300HZ	Fast 4+2 1400HZ	Fast 4+2 2300HZ
Radionics, Inc.	D6500				3x1	3x1	4x2	4x2
Silent Knight Security Corp.	9000	SIA 8	SIA 20		SK 3/1	SK 3/1	SK 4+2	SK 4+2
Silent Knight Security Corp.	9500	SIA DCS	SIA DCS	Ademco Contact ID	SK 3/1	SK 3/1	SK 4+2	SK 4+2
Silent Knight Security Corp.	9800	SIA DCS	SIA DCS	Ademco Contact ID	SK 3/1	SK 3/1	SK 4+2	SK 4+2

413699 EVENT CODES

Event Type	SIA DCS (8 or 20)	Ademco Contact ID	3/1 * 1400HZ or 2300HZ	4/2 ** 1400HZ or 2300HZ
Fire Alarm	FAxyz	111000xyz	0	01
Sprinkler Alarm	SAxyz	111300xyz	0	02
Fire Alarm Restore	FHxyz	311000xyz	2	21
Sprinkler Alarm Restore	SHxyz	311300xyz	2	22
Fire Supervisory	FSxyz	120000xyz	6	64
Sprinkler Supervisory	SSxyz	120300xyz	6	66
AC Restore	ARxyz	330100xyz	7	70
Power Up	RRxyz	130500xyz	7	70
Fire Unbypass	FUxyz	357100xyz	7	71
Phone Line 1 Restore	LRxyz	335100xyz	7	71
Phone Line 2 Restore	LRxyz	335200xyz	7	72
Fire Trouble Restore	FJxyz	337300xyz	7	73
Fire Restore	FRxyz	311000xyz	7	74
Sprinkler Trouble Restore	SJxyz	320300xyz	7	75
Sprinkler Restore	SRxyz	320300xyz	7	76
System Battery Restore	YRxyz	330200xyz	7	77
AC Trouble	ATxyz	130100xyz	8	80
Fire Bypass	FBxyz	157100xyz	8	81
Phone Line 1 Trouble	LTxyz	135100xyz	8	81
Phone Line 2 Trouble	LTxyz	135200xyz	8	82
Fire Trouble	FTxyz	137300xyz	8	83
Data Lost	RTxyz	135400xyz	8	84
Sprinkler Trouble	STxyz	120300xyz	8	85
System Battery Trouble	YTxyz	130200xyz	8	87
Fire Test Begin	Flxyz	160400xyz	9	90
Fire Test End	FKxyz	360400xyz	9	92
Automatic Test	RPxyz	160200xyz	9	93
Manual Test	RXxyz	160100xyz	9	94

* The 1-digit code is programmable (3/1 codes).

** The first digit is programmable (3/1 codes)

EVENT CODE IDENTIFER DESCRIPTIONS

	x	y	z
Sensor	0	Address (00-99)	
Module	1	Address (00-99)	
NAC Trouble	2	Circuit (01-04)	
GND Trouble	3	0	0
	4		
	5		
	6		
	7		
	8		
	9		

FCC Requirements - Part 68

This equipment complies with Part 68 of the Federal Communication Commission (FCC) Rules and Regulations. On the bottom is a label that contains, among other information, the FCC Registration Number and Ringer Equivalence Number (REN) for this equipment. If requested, this information must be provided to the telephone company.

FCC Registration Number: ABK USA-34988-AL-E

USOC telephone jack: RJ31X

Ringer Equivalence Number (REN): 0.4B

The REN is useful to determine the quantity of devices which may connect to the telephone line. Excessive REN's on the telephone line may result in the devices not ringing in response to an incoming call. In most, but not all areas, the sum of the REN's should not exceed five (5.0). To be certain of the number of devices that may be connected to the line, as determined by the total REN's, contact the telephone company to determine the maximum REN for the calling area.

If the Model 413699 equipment causes harm to the telephone network, the telephone company will notify you in advance that temporary discontinuance of service may be required. If advance notice is not practical, the telephone company will notify you of the discontinuance as soon as possible. Also, you will be advised of your right to file a complaint with the FCC if you believe it is necessary.

The telephone company may make changes in its facilities, equipment, operations or procedures that could affect the operation of your telephone equipment. If this happens, the telephone company will provide advance notice so that you can modify your equipment as required to maintain uninterrupted service.

If you experience trouble with the DACT Board for repair and/or warranty information please contact:

Faraday, LLC / 805 S. Maumee Street / Tecumseh, Michigan 49286 / 517-423-2111

If the trouble is causing harm to the telephone network, the telephone company may request you disconnect to equipment from the network until the problem is solved. You should not attempt to repair this equipment yourself. This equipment contains no customer or user serviceable parts.

This device may not be used on public coin or party line services.

Changes or modifications not expressly approved by Faraday, LLC could void your authority to operate this equipment.

INSTALLATION INSTRUCTIONS AND WIRING FOR AUXILIARY POWER SUPPLY CAT. NO. APS-1 P/N 12408

The 12408 Auxiliary Power Supply is an optional accessory for a fire alarm system control unit. This unit provides two power supply outputs, each can supply up to 1.5 amps of current, for a total of 3 amps of alarm current. The power supply is limited to a total of 2 amps of normal standby current. A dry contact trouble output is provided which can be monitored by the fire alarm system control unit. The 12408 also provides ground fault supervision of the power supply outputs.

PARTS SUPPLIED

1	12408-120 or Auxiliary Power Supply
	12408-240
1	443269 Screwdriver
1	446066 Instruction Sheet

Step 1.) Installation is to be done by qualified personnel who have thoroughly read and understood this instruction sheet.

CAUTION: It is recommended that the p.c. board be removed for any procedure that may cause dust, metal shavings, grease or any such matter that may affect the circuit board and/or parts.

12408 DIMENSIONS

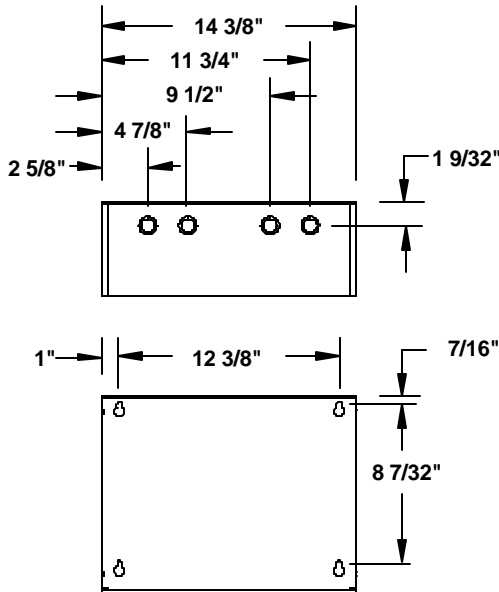

Step 2.) Disconnect all power into system, including batteries.

Step 3.) Mount backbox as required. If the power supply is to be mounted semi-flush, the backbox may be mounted up to 3.5" into the wall. Place the 12409 Semi-Flush Trim around the backbox and secure to the wall with four #10 x 3/4" wood screws (P/N 940454).

NOTE: The screw type may be required to be different depending on the wall material.

Step 4.) Attach conduit and run wires as required.

NOTE: The nonpower-limited wiring must be run in separate conduit and maintain 1/4" separation from power-limited wiring.

Step 5.) Connect wires to auxiliary power supply as required.

Step 6.) Apply power to system.

Step 7.) Check for proper operation of functions.

12408 SURFACE MOUNTING

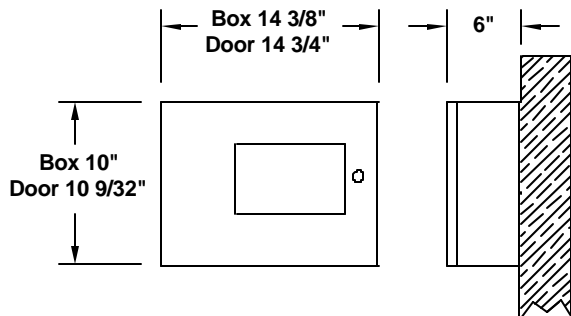

12408 SEMI-FLUSH MOUNTING

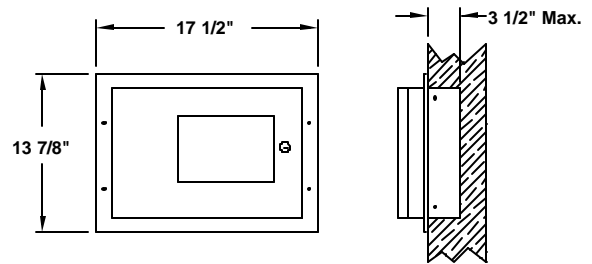

NOTE: See box dimensions at left for opening size.

12408 WIRING

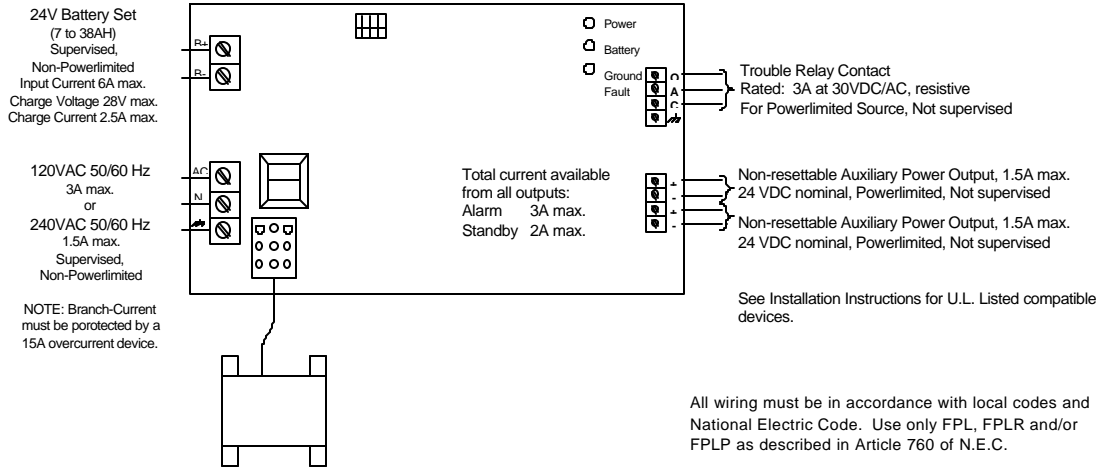

Devices for auxiliary power outputs

The following lists compatible devices for the auxiliary power outputs.

- Door Holders
- Relays
- Four-Wire (Separately Powered) Heat & Smoke Detectors
- Notification Appliances

Door Holders

Faraday Cat. No.	Mfg Part Number	Description
R.S.G. Inc.		
9552	DH-24120FC1	Door Holder
9553	DH-24120SC1	Door Holder
9554	DH-24120GC1	Door Holder
9555	DH-24120GC2	Door Holder
Edwards Co.		
1501-002	1501-G1	Door Holder
1502-002	1502-G1	Door Holder
1503-002	1503-G1	Door Holder
1504-002	1504-G1	Door Holder
1505-002	1505-G1	Door Holder
1508-002	1508-G1	Door Holder
1509-002	1509-G1	Door Holder

Relays

Faraday Cat. No.	Mfg Part Number	Description
Faraday LLC		
R711-1	711-1	Remote Relay Unit
Air Products & Controls		
R712-1	MR-101/C	Remote Relay Unit
R712-2	MR-201/C	Remote Relay Unit
R712-4	MR-104/C	Remote Relay Unit
R712-8	MR-204/C	Remote Relay Unit
9273	PAM-4	E.O.L. Relay
System Sensor		
PM6849	A77-716B	E.O.L. Relay

Notes:

1. For specific wiring and installation information, read the instructions provided with each device.

Four-Wire (Separately Powered) Smoke & Heat Detectors

Faraday Detector w/Base	Mfg Detector w/Base	Maximum Standby Current	Maximum Alarm Current	Notes
Air Products & Controls				
9269	RW-2W-NA	0.081mA	115mA	Must use EOL Relay
9270	RW-2W-PA	0.110mA	115mA	Must use EOL Relay
Apollo Fire Detectors Limited				
9260 w/9266	55000-350 w/45681-227	0.110mA	130mA	Must use EOL Relay
9261 w/9266	55000-250 w/45681-227	0.081mA	130mA	Must use EOL Relay
9264 w/9266	55000-153 w/45681-227	0.057mA	130mA	Must use EOL Relay
9274 w/9266	55000-152 w/45681-227	0.057mA	130mA	Must use EOL Relay
System Sensor				
9377	1424	0.100mA	41mA	Must use EOL Relay
9378	2424	0.120mA	41mA	Must use EOL Relay
9379	2424TH	0.120mA	41mA	Must use EOL Relay
9337	112/24	0.050mA	25mA	Must use EOL Relay
9338	2112/24	0.050mA	25mA	Must use EOL Relay
9339	2112/24T	0.050mA	25mA	Must use EOL Relay
9340	2112/24TSRB	15mA	45mA	Must use EOL Relay
9358 w/9362	1451 w/B402B	0.120mA	41mA	Must use EOL Relay
9359 w/9362	2451 w/B402B	0.120mA	41mA	Must use EOL Relay
9360 w/9362	2451TH w/B402B	0.120mA	41mA	Must use EOL Relay
9447 w/9362	5451 w/B402B	0.120mA	39mA	Must use EOL Relay
9421 w/9362	4451HT w/B402B	0.120mA	39mA	Must use EOL Relay
9164	DH400ACDCI	25mA	110mA	Must use 6 wires
9165	DH400ACDCP	25mA	110mA	Must use 6 wires
9175	6424	10mA	28.4mA	Must use EOL Relay and 6 wires

Notes:

1. For specific wiring and installation information, read the instructions provided with each device.
2. Each 9273 EOL Relay requires 15 mA standby current.

Compatible Notification Appliances

Catalog Number	Description	Audible Voltage	Audible Current	Strobe Voltage	Strobe Current
446(*1)	Bell-Vibrating	21-30 VDC	0.110A		
476(*1)	Bell-Vibrating	21-30VDC	0.070A		
477(*1)	Bell-Single Stroke	21-30VDC	0.360A		
2700-E	Strobe Light			20-31VDC	0.059A
2700-G	Strobe Light			20-31VDC	0.089A
2700-J	Strobe Light			20-31VDC	0.155A
2700-K	Strobe Light			20-31VDC	0.164A
2700-L	Strobe Light			20-31VDC	0.249A
2700-M (*2)	Sync Strobe Light			20-31VDC	0.059A
2700-R (*2)	Sync Strobe Light			20-31VDC	0.088A
2700-T (*2)	Sync Strobe Light			20-31VDC	0.154A
2700-Y (*2)	Sync Strobe Light			20-31VDC	0.170A
2700-Z (*2)	Sync Strobe Light			20-31VDC	0.249A
2701-E	Strobe Light			20-31VDC	0.059A
2701-G	Strobe Light			20-31VDC	0.089A
2701-J	Strobe Light			20-31VDC	0.155A
2701-K	Strobe Light			20-31VDC	0.164A
2701-L	Strobe Light			20-31VDC	0.249A
2701-M (*2)	Sync Strobe Light			20-31VDC	0.059A
2701-R (*2)	Sync Strobe Light			20-31VDC	0.088A
2701-T (*2)	Sync Strobe Light			20-31VDC	0.154A

Catalog Number	Description	Audible Voltage	Audible Current	Strobe Voltage	Strobe Current
2701-Y (*2)	Sync Strobe Light			20-31VDC	0.170A
2701-Z (*2)	Sync Strobe Light			20-31VDC	0.249A
2705-E	WP Strobe Light			20-31VDC	0.059A
2705-L	WP Strobe Light			20-31VDC	0.249A
2705-M (*2)	WP Sync Strobe Light			20-31VDC	0.059A
2705-Z (*2)	WP Sync Strobe Light			20-31VDC	0.249A
2820 (*2)	Sync Electronic Horn	20-31VDC	0.030A		
2821 (*2)	Sync Electronic Horn	20-31VDC	0.030A		
2824-M (*3)	Sync Electronic Horn w/Sync Strobe	20-31VDC	0.030A	20-31VDC	0.059A
2824-R (*3)	Sync Electronic Horn w/Sync Strobe	20-31VDC	0.030A	20-31VDC	0.088A
2824-T (*3)	Sync Electronic Horn w/Sync Strobe	20-31VDC	0.030A	20-31VDC	0.154A
2824-Y (*3)	Sync Electronic Horn w/Sync Strobe	20-31VDC	0.030A	20-31VDC	0.170A
2824-Z (*3)	Sync Electronic Horn w/Sync Strobe	20-31VDC	0.030A	20-31VDC	0.249A
2880	Electronic Signal-8T	20-31VDC	0.024-0.050A (*4)		
2881	Electronic Signal-8T	20-31VDC	0.024-0.050A (*4)		
2884-E	Electronic Signal-8T w/Strobe	20-31VDC	0.024-0.050A (*4)	20-31VDC	0.059A
2884-G	Electronic Signal-8T w/Strobe	20-31VDC	0.024-0.050A (*4)	20-31VDC	0.089A
2884-J	Electronic Signal-8T w/Strobe	20-31VDC	0.024-0.050A (*4)	20-31VDC	0.155A
2884-K	Electronic Signal-8T w/Strobe	20-31VDC	0.024-0.050A (*4)	20-31VDC	0.164A
2884-L	Electronic Signal-8T w/Strobe	20-31VDC	0.024-0.050A (*4)	20-31VDC	0.249A
2884-M (*2)	Electronic Signal-8T w/Sync Strobe	20-31VDC	0.024-0.050A (*4)	20-31VDC	0.059A
2884-R (*2)	Electronic Signal-8T w/Sync Strobe	20-31VDC	0.024-0.050A (*4)	20-31VDC	0.088A
2884-T (*2)	Electronic Signal-8T w/Sync Strobe	20-31VDC	0.024-0.050A (*4)	20-31VDC	0.154A
2884-Y (*2)	Electronic Signal-8T w/Sync Strobe	20-31VDC	0.024-0.050A (*4)	20-31VDC	0.170A
2884-Z (*2)	Electronic Signal-8T w/Sync Strobe	20-31VDC	0.024-0.050A (*4)	20-31VDC	0.249A
5300	Electronic Chime	21-30VDC	0.020A		
5303	Electronic Chime	21-30VDC	0.020A		
5304	Electronic Chime	21-30VDC	0.020A		
5305	Electronic Chime	21-30VDC	0.020A		
5306-(0,X)	Electronic Chime w/Strobe	21-30VDC	0.020A	21-30VDC	0.038A
5306-(A,B) (*2)	Electronic Chime w/Sync Strobe	21-30VDC	0.020A	20-31VDC	0.145A
5306-(H,U)	Electronic Chime w/Strobe	21-30VDC	0.020A	21-30VDC	0.075A
5306-(N,W)	Electronic Chime w/Strobe	21-30VDC	0.020A	21-32VDC	0.079A
5306-C (*2)	Electronic Chime w/Sync Strobe	21-30VDC	0.020A	20-31VDC	0.285A
5306-D	Electronic Chime w/Strobe	21-30VDC	0.020A	21-32VDC	0.175A
5306-S	Electronic Chime w/Strobe	21-30VDC	0.020A	21-32VDC	0.245A
5307-(0,X)	Electronic Chime w/Strobe	21-30VDC	0.020A	21-30VDC	0.038A
5307-(A,B) (*2)	Electronic Chime w/Sync Strobe	21-30VDC	0.020A	20-31VDC	0.145A
5307-(H,U)	Electronic Chime w/Strobe	21-30VDC	0.020A	21-30VDC	0.075A
5307-(N,W)	Electronic Chime w/Strobe	21-30VDC	0.020A	21-32VDC	0.079A
5307-C (*2)	Electronic Chime w/Sync Strobe	21-30VDC	0.020A	20-31VDC	0.285A
5307-D	Electronic Chime w/Strobe	21-30VDC	0.020A	21-32VDC	0.175A
5307-S	Electronic Chime w/Strobe	21-30VDC	0.020A	21-32VDC	0.245A
5308-(0,X)	Electronic Chime w/Strobe	21-30VDC	0.020A	21-30VDC	0.038A
5308-(A,B) (*2)	Electronic Chime w/Sync Strobe	21-30VDC	0.020A	20-31VDC	0.145A
5308-(H,U)	Electronic Chime w/Strobe	21-30VDC	0.020A	21-30VDC	0.075A
5308-(N,W)	Electronic Chime w/Strobe	21-30VDC	0.020A	21-32VDC	0.079A
5320	Slow Whoop	21-30VDC	0.150A		
5323	Slow Whoop	21-30VDC	0.150A		
5324	Slow Whoop	21-30VDC	0.150A		
5325	Slow Whoop	21-30VDC	0.150A		
5326-(0,X)	Slow Whoop w/Strobe	21-30VDC	0.150A	21-30VDC	0.038A
5326-(A,B) (*2)	Slow Whoop w/Sync Strobe	21-30VDC	0.150A	20-31VDC	0.145A
5326-(H,U)	Slow Whoop w/Strobe	21-30VDC	0.150A	21-30VDC	0.075A
5326-(N,W)	Slow Whoop w/Strobe	21-30VDC	0.150A	21-32VDC	0.079A
5326-C (*2)	Slow Whoop w/Sync Strobe	21-30VDC	0.150A	20-31VDC	0.285A
5326-D	Slow Whoop w/Strobe	21-30VDC	0.150A	21-32VDC	0.175A
5326-S	Slow Whoop w/Strobe	21-30VDC	0.150A	21-32VDC	0.245A

Catalog Number	Description	Audible Voltage	Audible Current	Strobe Voltage	Strobe Current
5327-(0,X)	Slow Whoop w/Strobe	21-30VDC	0.150A	21-30VDC	0.038A
5327-(A,B) (*2)	Slow Whoop w/Sync Strobe	21-30VDC	0.150A	20-31VDC	0.145A
5327-(H,U)	Slow Whoop w/Strobe	21-30VDC	0.150A	21-30VDC	0.075A
5327-(N,W)	Slow Whoop w/Strobe	21-30VDC	0.150A	21-32VDC	0.079A
5327-C (*2)	Slow Whoop w/Sync Strobe	21-30VDC	0.150A	20-31VDC	0.285A
5327-D	Slow Whoop w/Strobe	21-30VDC	0.150A	21-32VDC	0.175A
5327-S	Slow Whoop w/Strobe	21-30VDC	0.150A	21-32VDC	0.245A
5328-(0,X)	Slow Whoop w/Strobe	21-30VDC	0.150A	21-30VDC	0.038A
5328-(A,B) (*2)	Slow Whoop w/Sync Strobe	21-30VDC	0.150A	20-31VDC	0.145A
5328-(H,U)	Slow Whoop w/Strobe	21-30VDC	0.150A	21-30VDC	0.075A
5328-(N,W)	Slow Whoop w/Strobe	21-30VDC	0.150A	21-32VDC	0.079A
5330	Electronic Horn-3T	21-32VDC	0.020-0.025A (*4)		
5333	Electronic Horn-3T	21-32VDC	0.020-0.025A (*4)		
5334	Electronic Horn-3T	21-32VDC	0.020-0.025A (*4)		
5335	Electronic Horn-3T	21-32VDC	0.020-0.025A (*4)		
5336-(0,X)	Electronic Horn-3T w/Strobe	21-32VDC	0.020-0.025A (*4)	21-30VDC	0.038A
5336-(A,B) (*2)	Electronic Horn-3T w/Sync Strobe	21-32VDC	0.020-0.025A (*4)	20-31VDC	0.145A
5336-(H,U)	Electronic Horn-3T w/Strobe	21-32VDC	0.020-0.025A (*4)	21-30VDC	0.075A
5336-(N,W)	Electronic Horn-3T w/Strobe	21-32VDC	0.020-0.025A (*4)	21-32VDC	0.079A
5336-C (*2)	Electronic Horn-3T w/Sync Strobe	21-32VDC	0.020-0.025A (*4)	20-31VDC	0.285A
5336-D	Electronic Horn-3T w/Strobe	21-32VDC	0.020-0.025A (*4)	21-32VDC	0.175A
5336-S	Electronic Horn-3T w/Strobe	21-32VDC	0.020-0.025A (*4)	21-32VDC	0.245A
5337-(0,X)	Electronic Horn-3T w/Strobe	21-32VDC	0.020-0.025A (*4)	21-30VDC	0.038A
5337-(A,B) (*2)	Electronic Horn-3T w/Sync Strobe	21-32VDC	0.020-0.025A (*4)	20-31VDC	0.145A
5337-(H,U)	Electronic Horn-3T w/Strobe	21-32VDC	0.020-0.025A (*4)	21-30VDC	0.075A
5337-(N,W)	Electronic Horn-3T w/Strobe	21-32VDC	0.020-0.025A (*4)	21-32VDC	0.079A
5337-C (*2)	Electronic Horn-3T w/Sync Strobe	21-32VDC	0.020-0.025A (*4)	20-31VDC	0.285A
5337-D	Electronic Horn-3T w/Strobe	21-32VDC	0.020-0.025A (*4)	21-32VDC	0.175A
5337-S	Electronic Horn-3T w/Strobe	21-32VDC	0.020-0.025A (*4)	21-32VDC	0.245A
5338-(0,X)	Electronic Horn-3T w/Strobe	21-32VDC	0.020-0.025A (*4)	21-30VDC	0.038A
5338-(A,B) (*2)	Electronic Horn-3T w/Sync Strobe	21-32VDC	0.020-0.025A (*4)	20-31VDC	0.145A
5338-(H,U)	Electronic Horn-3T w/Strobe	21-32VDC	0.020-0.025A (*4)	21-30VDC	0.075A
5338-(N,W)	Electronic Horn-3T w/Strobe	21-32VDC	0.020-0.025A (*4)	21-32VDC	0.079A
5340	Electronic Horn	21-32VDC	0.020A		
5343	Electronic Horn	21-32VDC	0.020A		
5344	Electronic Horn	21-32VDC	0.020A		
5345	Electronic Horn	21-32VDC	0.020A		
5346-(0,X)	Electronic Horn w/Strobe	21-32VDC	0.020A	21-30VDC	0.038A
5346-(A,B) (*2)	Electronic Horn w/Sync Strobe	21-32VDC	0.020A	20-31VDC	0.145A
5346-(H,U)	Electronic Horn w/Strobe	21-32VDC	0.020A	21-30VDC	0.075A
5346-(N,W)	Electronic Horn w/Strobe	21-32VDC	0.020A	21-32VDC	0.079A
5346-C (*2)	Electronic Horn w/Sync Strobe	21-32VDC	0.020A	20-31VDC	0.285A
5346-D	Electronic Horn w/Strobe	21-32VDC	0.020A	21-32VDC	0.175A
5346-S	Electronic Horn w/Strobe	21-32VDC	0.020A	21-32VDC	0.245A
5347-(0,X)	Electronic Horn w/Strobe	21-32VDC	0.020A	21-30VDC	0.038A
5347-(A,B) (*2)	Electronic Horn w/Sync Strobe	21-32VDC	0.020A	20-31VDC	0.145A
5347-(H,U)	Electronic Horn w/Strobe	21-32VDC	0.020A	21-30VDC	0.075A
5347-(N,W)	Electronic Horn w/Strobe	21-32VDC	0.020A	21-32VDC	0.079A
5347-C (*2)	Electronic Horn w/Sync Strobe	21-32VDC	0.020A	20-31VDC	0.285A
5347-D	Electronic Horn w/Strobe	21-32VDC	0.020A	21-32VDC	0.175A
5347-S	Electronic Horn w/Strobe	21-32VDC	0.020A	21-32VDC	0.245A
5348-(0,X)	Electronic Horn w/Strobe	21-32VDC	0.020A	21-30VDC	0.038A
5348-(A,B) (*2)	Electronic Horn w/Sync Strobe	21-32VDC	0.020A	20-31VDC	0.145A
5348-(H,U)	Electronic Horn w/Strobe	21-32VDC	0.020A	21-30VDC	0.075A
5348-(N,W)	Electronic Horn w/Strobe	21-32VDC	0.020A	21-32VDC	0.079A
5350	Electronic Horn-3T	21-32VDC	0.020-0.025A (*4)		
5353	Electronic Horn-3T	21-32VDC	0.020-0.025A (*4)		
5354	Electronic Horn-3T	21-32VDC	0.020-0.025A (*4)		

Catalog Number	Description	Audible Voltage	Audible Current	Strobe Voltage	Strobe Current
5355	Electronic Horn-3T	21-32VDC	0.020-0.025A (*4)		
5360	Electronic Horn	21-32VDC	0.020A		
5363	Electronic Horn	21-32VDC	0.020A		
5364	Electronic Horn	21-32VDC	0.020A		
5365	Electronic Horn	21-32VDC	0.020A		
5370	Electronic Signal-8T	12-32VDC	0.020-0.050A (*4)		
5373	Electronic Signal-8T	12-32VDC	0.020-0.050A (*4)		
5374	Electronic Signal-8T	12-32VDC	0.020-0.050A (*4)		
5375	Electronic Signal-8T	12-32VDC	0.020-0.050A (*4)		
5376-(A,B) (*2)	Electronic Signal-8T w/Sync Strobe	12-32VDC	0.020-0.050A (*4)	20-31VDC	0.145A
5376-(N,W)	Electronic Signal-8T w/Strobe	12-32VDC	0.020-0.050A (*4)	21-32VDC	0.079A
5376-C (*2)	Electronic Signal-8T w/Sync Strobe	12-32VDC	0.020-0.050A (*4)	20-31VDC	0.285A
5376-D	Electronic Signal-8T w/Strobe	12-32VDC	0.020-0.050A (*4)	21-32VDC	0.175A
5376-S	Electronic Signal-8T w/Strobe	12-32VDC	0.020-0.050A (*4)	21-32VDC	0.245A
5377-(A,B) (*2)	Electronic Signal-8T w/Sync Strobe	12-32VDC	0.020-0.050A (*4)	20-31VDC	0.145A
5377-(N,W)	Electronic Signal-8T w/Strobe	12-32VDC	0.020-0.050A (*4)	21-32VDC	0.079A
5377-C (*2)	Electronic Signal-8T w/Sync Strobe	12-32VDC	0.020-0.050A (*4)	20-31VDC	0.285A
5377-D	Electronic Signal-8T w/Strobe	12-32VDC	0.020-0.050A (*4)	21-32VDC	0.175A
5377-S	Electronic Signal-8T w/Strobe	12-32VDC	0.020-0.050A (*4)	21-32VDC	0.245A
5378-(A,B) (*2)	Electronic Signal-8T w/Sync Strobe	12-32VDC	0.020-0.050A (*4)	20-31VDC	0.145A
5378-(N,W)	Electronic Signal-8T w/Strobe	12-32VDC	0.020-0.050A (*4)	21-32VDC	0.079A
5380	Electronic Signal-8T	12-32VDC	0.020-0.050A (*4)		
5383	Electronic Signal-8T	12-32VDC	0.020-0.050A (*4)		
5384	Electronic Signal-8T	12-32VDC	0.020-0.050A (*4)		
5385	Electronic Signal-8T	12-32VDC	0.020-0.050A (*4)		
5386-(A,B) (*2)	Electronic Signal-8T w/Sync Strobe	12-32VDC	0.020-0.050A (*4)	20-31VDC	0.145A
5386-(N,W)	Electronic Signal-8T w/Strobe	12-32VDC	0.020-0.050A (*4)	21-32VDC	0.079A
5386-C (*2)	Electronic Signal-8T w/Sync Strobe	12-32VDC	0.020-0.050A (*4)	20-31VDC	0.285A
5386-D	Electronic Signal-8T w/Strobe	12-32VDC	0.020-0.050A (*4)	21-32VDC	0.175A
5386-S	Electronic Signal-8T w/Strobe	12-32VDC	0.020-0.050A (*4)	21-32VDC	0.245A
5387-(A,B) (*2)	Electronic Signal-8T w/Sync Strobe	12-32VDC	0.020-0.050A (*4)	20-31VDC	0.145A
5387-(N,W)	Electronic Signal-8T w/Strobe	12-32VDC	0.020-0.050A (*4)	21-32VDC	0.079A
5387-C (*2)	Electronic Signal-8T w/Sync Strobe	12-32VDC	0.020-0.050A (*4)	20-31VDC	0.285A
5387-D	Electronic Signal-8T w/Strobe	12-32VDC	0.020-0.050A (*4)	21-32VDC	0.175A
5387-S	Electronic Signal-8T w/Strobe	12-32VDC	0.020-0.050A (*4)	21-32VDC	0.245A
5388-(A,B) (*2)	Electronic Signal-8T w/Sync Strobe	12-32VDC	0.020-0.050A (*4)	20-31VDC	0.145A
5388-(N,W)	Electronic Signal-8T w/Strobe	12-32VDC	0.020-0.050A (*4)	21-32VDC	0.079A
5390	Electronic Chime	21-30VDC	0.020A		
5394-E	Electronic Chime w/Strobe	21-30VDC	0.020A	20-31VDC	0.059A
5394-G	Electronic Chime w/Strobe	21-30VDC	0.020A	20-31VDC	0.089A
5394-J	Electronic Chime w/Strobe	21-30VDC	0.020A	20-31VDC	0.155A
5394-K	Electronic Chime w/Strobe	21-30VDC	0.020A	20-31VDC	0.164A
5394-L	Electronic Chime w/Strobe	21-30VDC	0.020A	20-31VDC	0.249A
5394-M (*2)	Electronic Chime w/Sync Strobe	21-30VDC	0.020A	20-31VDC	0.059A
5394-R (*2)	Electronic Chime w/Sync Strobe	21-30VDC	0.020A	20-31VDC	0.088A
5394-T (*2)	Electronic Chime w/Sync Strobe	21-30VDC	0.020A	20-31VDC	0.154A
5394-Y (*2)	Electronic Chime w/Sync Strobe	21-30VDC	0.020A	20-31VDC	0.170A
5394-Z (*2)	Electronic Chime w/Sync Strobe	21-30VDC	0.020A	20-31VDC	0.249A
5395	Electronic Chime	21-30VDC	0.020A		
5398-E	Electronic Chime w/Strobe	21-30VDC	0.020A	20-31VDC	0.059A
5398-G	Electronic Chime w/Strobe	21-30VDC	0.020A	20-31VDC	0.089A
5398-J	Electronic Chime w/Strobe	21-30VDC	0.020A	20-31VDC	0.155A
5398-K	Electronic Chime w/Strobe	21-30VDC	0.020A	20-31VDC	0.164A
5398-L	Electronic Chime w/Strobe	21-30VDC	0.020A	20-31VDC	0.249A
5398-M (*2)	Electronic Chime w/Sync Strobe	21-30VDC	0.020A	20-31VDC	0.059A
5398-R (*2)	Electronic Chime w/Sync Strobe	21-30VDC	0.020A	20-31VDC	0.088A
5398-T (*2)	Electronic Chime w/Sync Strobe	21-30VDC	0.020A	20-31VDC	0.154A
5398-Y (*2)	Electronic Chime w/Sync Strobe	21-30VDC	0.020A	20-31VDC	0.170A

Catalog Number	Description	Audible Voltage	Audible Current	Strobe Voltage	Strobe Current
5398-Z (*2)	Electronic Chime w/Sync Strobe	21-30VDC	0.020A	20-31VDC	0.249A
5405	Sync Control Unit	20-31VDC	.020A		
5406	Sync Control Unit	20-31VDC	.020A		
5508-(0,X)	Strobe Light			21-30VDC	0.038A
5508-(A,B) (*2)	Sync Strobe Light			20-31VDC	0.145A
5508-(H,U)	Strobe Light			21-30VDC	0.075A
5508-(N,W)	Strobe Light			21-32VDC	0.079A
5508-C (*2)	Sync Strobe Light			20-31VDC	0.285A
5508-D	Strobe Light			21-32VDC	0.175A
5508-S	Strobe Light			21-32VDC	0.245A
5509-(0,X)	Strobe Light			21-30VDC	0.038A
5509-(H,U)	Strobe Light			21-30VDC	0.075A
5510-(0,X)	Strobe Light			21-30VDC	0.038A
5510-(A,B) (*2)	Sync Strobe Light			20-31VDC	0.145A
5510-(N,W)	Strobe Light			21-32VDC	0.079A
5511-(0,X)	Strobe Light			21-30VDC	0.038A
5511-(A,B) (*2)	Sync Strobe Light			20-31VDC	0.145A
5511-(H,U)	Strobe Light			21-30VDC	0.075A
5511-(N,W)	Strobe Light			21-32VDC	0.079A
5511-C (*2)	Sync Strobe Light			20-31VDC	0.285A
5511-D	Strobe Light			21-32VDC	0.175A
5511-S	Strobe Light			21-32VDC	0.245A
5512-(0,X)	Strobe Light			21-30VDC	0.038A
5512-(A,B) (*2)	Sync Strobe Light			20-31VDC	0.145A
5512-(H,U)	Strobe Light			21-30VDC	0.075A
5512-(N,W)	Strobe Light			21-32VDC	0.079A
5512-C (*2)	Sync Strobe Light			20-31VDC	0.285A
5512-D	Strobe Light			21-32VDC	0.175A
5512-S	Strobe Light			21-32VDC	0.245A
5516-(0,X)	Strobe Light			21-30VDC	0.038A
5516-(A,B) (*2)	Sync Strobe Light			20-31VDC	0.145A
5516-(H,U)	Strobe Light			21-30VDC	0.075A
5516-(N,W)	Strobe Light			21-32VDC	0.079A
5516-C (*2)	Sync Strobe Light			20-31VDC	0.285A
5516-D	Strobe Light			21-32VDC	0.175A
5516-S	Strobe Light			21-32VDC	0.245A
5517-(0,X)	Strobe Light			21-30VDC	0.038A
5517-(A,B) (*2)	Sync Strobe Light			20-31VDC	0.145A
5517-(H,U)	Strobe Light			21-30VDC	0.075A
5517-(N,W)	Strobe Light			21-32VDC	0.079A
5517-C (*2)	Sync Strobe Light			20-31VDC	0.285A
5517-D	Strobe Light			21-32VDC	0.175A
5517-S	Strobe Light			21-32VDC	0.245A
5518-(0,X)	Strobe Light			21-30VDC	0.038A
5518-(A,B) (*2)	Sync Strobe Light			20-31VDC	0.145A
5518-(H,U)	Strobe Light			21-30VDC	0.075A
5518-(N,W)	Strobe Light			21-32VDC	0.079A
5519-(A,B) (*2)	Sync Strobe Light			20-31VDC	0.145A
5519-(N,W)	Strobe Light			21-32VDC	0.079A
5519-C (*2)	Sync Strobe Light			20-31VDC	0.285A
5519-D	Strobe Light			21-32VDC	0.175A
5519-S	Strobe Light			21-32VDC	0.245A
5521-(0,X)	Strobe Light			21-30VDC	0.038A
5521-(A,B) (*2)	Sync Strobe Light			20-31VDC	0.145A
5521-(H,U)	Strobe Light			21-30VDC	0.075A
5521-(N,W)	Strobe Light			21-32VDC	0.079A
5521-C (*2)	Sync Strobe Light			20-31VDC	0.285A
5521-D	Strobe Light			21-32VDC	0.175A

Catalog Number	Description	Audible Voltage	Audible Current	Strobe Voltage	Strobe Current
5521-S	Strobe Light			21-32VDC	0.245A
5521C-(A,B) (*2)	Sync Strobe Light			20-31VDC	0.145A
5521C-(N,W)	Strobe Light			21-32VDC	0.079A
5521C-C (*2)	Sync Strobe Light			20-31VDC	0.285A
5521C-D	Strobe Light			21-32VDC	0.175A
5521C-S	Strobe Light			21-32VDC	0.245A
5522-(0,X)	Strobe Light			21-30VDC	0.038A
5522-(A,B) (*2)	Sync Strobe Light			20-31VDC	0.145A
5522-(H,U)	Strobe Light			21-30VDC	0.075A
5522-(N,W)	Strobe Light			21-32VDC	0.079A
5522-C (*2)	Sync Strobe Light			20-31VDC	0.285A
5522-D	Strobe Light			21-32VDC	0.175A
5522-S	Strobe Light			21-32VDC	0.245A
5522C-(A,B) (*2)	Sync Strobe Light			20-31VDC	0.145A
5522C-(N,W)	Strobe Light			21-32VDC	0.079A
5522C-C (*2)	Sync Strobe Light			20-31VDC	0.285A
5522C-D	Strobe Light			21-32VDC	0.175A
5522C-S	Strobe Light			21-32VDC	0.245A
6120	Horn	21-30VDC	0.035A		
6140	Horn	21-30VDC	0.065A		
6220	Horn	21-30VDC	0.038A		
6223	Horn	21-30VDC	0.038A		
6224	Horn	21-30VDC	0.038A		
6225	Horn	21-30VDC	0.038A		
6226-(A,B) (*2)	Horn w/Sync Strobe	21-30VDC	0.038A	20-31VDC	0.145A
6226-(N,W)	Horn w/Strobe	21-30VDC	0.038A	21-32VDC	0.079A
6226-C (*2)	Horn w/Sync Strobe	21-30VDC	0.038A	20-31VDC	0.285A
6226-D	Horn w/Strobe	21-30VDC	0.038A	21-32VDC	0.175A
6226-S	Horn w/Strobe	21-30VDC	0.038A	21-32VDC	0.245A
6227-(A,B) (*2)	Horn w/Sync Strobe	21-30VDC	0.038A	20-31VDC	0.145A
6227-(N,W)	Horn w/Strobe	21-30VDC	0.038A	21-32VDC	0.079A
6227-C (*2)	Horn w/Sync Strobe	21-30VDC	0.038A	20-31VDC	0.285A
6227-D	Horn w/Strobe	21-30VDC	0.038A	21-32VDC	0.175A
6227-S	Horn w/Strobe	21-30VDC	0.038A	21-32VDC	0.245A
6228-(A,B) (*2)	Horn w/Sync Strobe	21-30VDC	0.038A	20-31VDC	0.145A
6228-(N,W)	Horn w/Strobe	21-30VDC	0.038A	21-32VDC	0.079A
6230	Horn	21-30VDC	0.038A		
6234-E	Horn w/Strobe	21-30VDC	0.038A	20-31VDC	0.059A
6234-G	Horn w/Strobe	21-30VDC	0.038A	20-31VDC	0.089A
6234-J	Horn w/Strobe	21-30VDC	0.038A	20-31VDC	0.155A
6234-K	Horn w/Strobe	21-30VDC	0.038A	20-31VDC	0.164A
6234-L	Horn w/Strobe	21-30VDC	0.038A	20-31VDC	0.249A
6234-M (*2)	Horn w/Sync Strobe	21-30VDC	0.038A	20-31VDC	0.059A
6234-R (*2)	Horn w/Sync Strobe	21-30VDC	0.038A	20-31VDC	0.088A
6234-T (*2)	Horn w/Sync Strobe	21-30VDC	0.038A	20-31VDC	0.154A
6234-Y (*2)	Horn w/Sync Strobe	21-30VDC	0.038A	20-31VDC	0.170A
6234-Z (*2)	Horn w/Sync Strobe	21-30VDC	0.038A	20-31VDC	0.249A
6235-E	WP Horn w/ Strobe	21-30VDC	0.038A	20-31VDC	0.059A
6235-L	WP Horn w/ Strobe	21-30VDC	0.038A	20-31VDC	0.249A
6235-M (*2)	WP Horn w/ Sync Strobe	21-30VDC	0.038A	20-31VDC	0.059A
6235-Z (*2)	WP Horn w/ Sync Strobe	21-30VDC	0.038A	20-31VDC	0.249A
6238-E	Horn w/Strobe	21-30VDC	0.038A	20-31VDC	0.059A
6238-G	Horn w/Strobe	21-30VDC	0.038A	20-31VDC	0.089A
6238-J	Horn w/Strobe	21-30VDC	0.038A	20-31VDC	0.155A
6238-K	Horn w/Strobe	21-30VDC	0.038A	20-31VDC	0.164A
6238-L	Horn w/Strobe	21-30VDC	0.038A	20-31VDC	0.249A
6238-M (*2)	Horn w/Sync Strobe	21-30VDC	0.038A	20-31VDC	0.059A
6238-R (*2)	Horn w/Sync Strobe	21-30VDC	0.038A	20-31VDC	0.088A

Catalog Number	Description	Audible Voltage	Audible Current	Strobe Voltage	Strobe Current
6238-T (*2)	Horn w/Sync Strobe	21-30VDC	0.038A	20-31VDC	0.154A
6238-Y (*2)	Horn w/Sync Strobe	21-30VDC	0.038A	20-31VDC	0.170A
6238-Z (*2)	Horn w/Sync Strobe	21-30VDC	0.038A	20-31VDC	0.249A
6240	Horn	21-30VDC	0.065A		
6243	Horn	21-30VDC	0.065A		
6244	Horn	21-30VDC	0.065A		
6245	Horn	21-30VDC	0.065A		
6246-(A,B) (*2)	Horn w/Sync Strobe	21-30VDC	0.065A	20-31VDC	0.145A
6246-(N,W)	Horn w/Strobe	21-30VDC	0.065A	21-32VDC	0.079A
6246-C (*2)	Horn w/Sync Strobe	21-30VDC	0.065A	20-31VDC	0.285A
6246-D	Horn w/Strobe	21-30VDC	0.065A	21-32VDC	0.175A
6246-S	Horn w/Strobe	21-30VDC	0.065A	21-32VDC	0.245A
6247-(A,B) (*2)	Horn w/Sync Strobe	21-30VDC	0.065A	20-31VDC	0.145A
6247-(N,W)	Horn w/Strobe	21-30VDC	0.065A	21-32VDC	0.079A
6247-C (*2)	Horn w/Sync Strobe	21-30VDC	0.065A	20-31VDC	0.285A
6247-D	Horn w/Strobe	21-30VDC	0.065A	21-32VDC	0.175A
6247-S	Horn w/Strobe	21-30VDC	0.065A	21-32VDC	0.245A
6248-(A,B) (*2)	Horn w/Sync Strobe	21-30VDC	0.065A	20-31VDC	0.145A
6248-(N,W)	Horn w/Strobe	21-30VDC	0.065A	21-32VDC	0.079A
6250	Horn	21-30VDC	0.065A		
6254-E	Horn w/Strobe	21-30VDC	0.065A	20-31VDC	0.059A
6254-G	Horn w/Strobe	21-30VDC	0.065A	20-31VDC	0.089A
6254-J	Horn w/Strobe	21-30VDC	0.065A	20-31VDC	0.155A
6254-K	Horn w/Strobe	21-30VDC	0.065A	20-31VDC	0.164A
6254-L	Horn w/Strobe	21-30VDC	0.065A	20-31VDC	0.249A
6254-M (*2)	Horn w/Sync Strobe	21-30VDC	0.065A	20-31VDC	0.059A
6254-R (*2)	Horn w/Sync Strobe	21-30VDC	0.065A	20-31VDC	0.088A
6254-T (*2)	Horn w/Sync Strobe	21-30VDC	0.065A	20-31VDC	0.154A
6254-Y (*2)	Horn w/Sync Strobe	21-30VDC	0.065A	20-31VDC	0.170A
6254-Z (*2)	Horn w/Sync Strobe	21-30VDC	0.065A	20-31VDC	0.249A
6235-E	WP Horn w/ Strobe	21-30VDC	0.065A	20-31VDC	0.059A
6235-L	WP Horn w/ Strobe	21-30VDC	0.065A	20-31VDC	0.249A
6235-M (*2)	WP Horn w/ Sync Strobe	21-30VDC	0.065A	20-31VDC	0.059A
6235-Z (*2)	WP Horn w/ Sync Strobe	21-30VDC	0.065A	20-31VDC	0.249A
6258-E	Horn w/Strobe	21-30VDC	0.065A	20-31VDC	0.059A
6258-G	Horn w/Strobe	21-30VDC	0.065A	20-31VDC	0.089A
6258-J	Horn w/Strobe	21-30VDC	0.065A	20-31VDC	0.155A
6258-K	Horn w/Strobe	21-30VDC	0.065A	20-31VDC	0.164A
6258-L	Horn w/Strobe	21-30VDC	0.065A	20-31VDC	0.249A
6258-M (*2)	Horn w/Sync Strobe	21-30VDC	0.065A	20-31VDC	0.059A
6258-R (*2)	Horn w/Sync Strobe	21-30VDC	0.065A	20-31VDC	0.088A
6258-T (*2)	Horn w/Sync Strobe	21-30VDC	0.065A	20-31VDC	0.154A
6258-Y (*2)	Horn w/Sync Strobe	21-30VDC	0.065A	20-31VDC	0.170A
6258-Z (*2)	Horn w/Sync Strobe	21-30VDC	0.065A	20-31VDC	0.249A
6300	Mini-Horn	20-31VDC	0.025A		
6301	Mini-Horn	20-31VDC	0.025A		
6302-(A,B) (*2)	Mini-Horn w/Sync Strobe	20-31VDC	0.025A	20-31VDC	0.145A
6302-(N,W)	Mini-Horn w/Strobe	20-31VDC	0.025A	21-32VDC	0.079A
6302-C (*2)	Mini-Horn w/Sync Strobe	20-31VDC	0.025A	20-31VDC	0.285A
6302-D	Mini-Horn w/Strobe	20-31VDC	0.025A	21-32VDC	0.175A
6302-S	Mini-Horn w/Strobe	20-31VDC	0.025A	21-32VDC	0.245A
6304-E	Mini-Horn w/Strobe	20-31VDC	0.025A	20-31VDC	0.059A
6304-G	Mini-Horn w/Strobe	20-31VDC	0.025A	20-31VDC	0.089A
6304-J	Mini-Horn w/Strobe	20-31VDC	0.025A	20-31VDC	0.155A
6304-K	Mini-Horn w/Strobe	20-31VDC	0.025A	20-31VDC	0.164A
6304-L	Mini-Horn w/Strobe	20-31VDC	0.025A	20-31VDC	0.249A
6304-M (*2)	Mini-Horn w/Sync Strobe	20-31VDC	0.025A	20-31VDC	0.059A
6304-R (*2)	Mini-Horn w/Sync Strobe	20-31VDC	0.025A	20-31VDC	0.088A

Catalog Number	Description	Audible Voltage	Audible Current	Strobe Voltage	Strobe Current
6304-T (*2)	Mini-Horn w/Sync Strobe	20-31VDC	0.025A	20-31VDC	0.154A
6304-Y (*2)	Mini-Horn w/Sync Strobe	20-31VDC	0.025A	20-31VDC	0.170A
6304-Z (*2)	Mini-Horn w/Sync Strobe	20-31VDC	0.025A	20-31VDC	0.249A
6310	Mini-Horn-S/T	20-31VDC	0.025A		
6311	Mini-Horn-S/T	20-31VDC	0.025A		
6312-(A,B) (*2)	Mini-Horn-S/T w/Sync Strobe	20-31VDC	0.025A	20-31VDC	0.145A
6312-(N,W)	Mini-Horn-S/T w/Strobe	20-31VDC	0.025A	21-32VDC	0.079A
6312-C (*2)	Mini-Horn-S/T w/Sync Strobe	20-31VDC	0.025A	20-31VDC	0.285A
6312-D	Mini-Horn-S/T w/Strobe	20-31VDC	0.025A	21-32VDC	0.175A
6312-S	Mini-Horn-S/T w/Strobe	20-31VDC	0.025A	21-32VDC	0.245A
6314-E	Mini-Horn-S/T w/Strobe	20-31VDC	0.025A	20-31VDC	0.059A
6314-G	Mini-Horn-S/T w/Strobe	20-31VDC	0.025A	20-31VDC	0.089A
6314-J	Mini-Horn-S/T w/Strobe	20-31VDC	0.025A	20-31VDC	0.155A
6314-K	Mini-Horn-S/T w/Strobe	20-31VDC	0.025A	20-31VDC	0.164A
6314-L	Mini-Horn-S/T w/Strobe	20-31VDC	0.025A	20-31VDC	0.230A
6314-M (*2)	Mini-Horn-S/T w/Sync Strobe	20-31VDC	0.025A	20-31VDC	0.059A
6314-R (*2)	Mini-Horn-S/T w/Sync Strobe	20-31VDC	0.025A	20-31VDC	0.088A
6314-T (*2)	Mini-Horn-S/T w/Sync Strobe	20-31VDC	0.025A	20-31VDC	0.154A
6314-Y (*2)	Mini-Horn-S/T w/Sync Strobe	20-31VDC	0.025A	20-31VDC	0.170A
6314-Z (*2)	Mini-Horn-S/T w/Sync Strobe	20-31VDC	0.025A	20-31VDC	0.249A
6320 (*2)	Sync Electronic Horn	20-31VDC	0.030A		
6321 (*2)	Sync Electronic Horn	20-31VDC	0.030A		
6322-(A,B) (*3)	Sync Electronic Horn w/Sync Strobe	20-31VDC	0.030A	20-31VDC	0.145A
6322-C (*3)	Sync Electronic Horn w/Sync Strobe	20-31VDC	0.030A	20-31VDC	0.285A
6380	Electronic Signal-8T	20-31VDC	0.024-0.050A (*4)		
6381	Electronic Signal-8T	20-31VDC	0.024-0.050A (*4)		
6382-(A,B) (*2)	Electronic Signal-8T w/Sync Strobe	20-31VDC	0.024-0.050A (*4)	20-31VDC	0.145A
6382-(N,W)	Electronic Signal-8T w/Strobe	20-31VDC	0.024-0.050A (*4)	21-32VDC	0.079A
6382-C (*2)	Electronic Signal-8T w/Sync Strobe	20-31VDC	0.024-0.050A (*4)	20-31VDC	0.285A
6382-D	Electronic Signal-8T w/Strobe	20-31VDC	0.024-0.050A (*4)	21-32VDC	0.175A
6382-S	Electronic Signal-8T w/Strobe	20-31VDC	0.024-0.050A (*4)	21-32VDC	0.245A

Key:

- (*1) 1=10" gong, 4=4" gong, 5=chime, 6=6" gong, 8=8" gong
- (*2) Sync Strobe Light or Sync Electronic Horn require 5405 or 5406 Sync Control Module
- (*3) Sync Electronic Horn and Sync Strobe Light require 5405 or 5406 Sync Control Module
- (*4) See Installation Instructions for the current of the desired tone.

Cat. No. xxxx-0 = Strobe Light (UL1638 4.5cd)	Cat. No. xxxx-E = Strobe Light (UL1971 15/75cd)
Cat. No. xxxx-H = Strobe Light (UL1638 15cd)	Cat. No. xxxx-G = Strobe Light (UL1971 30/75cd)
Cat. No. xxxx-X = Strobe Light (UL1638 30cd)	Cat. No. xxxx-J = Strobe Light (UL1971 60/75cd)
Cat. No. xxxx-U = Strobe Light (UL1638 120cd)	Cat. No. xxxx-K = Strobe Light (UL1971 75cd)
Cat. No. xxxx-N = Strobe Light (UL1971 15cd)	Cat. No. xxxx-L = Strobe Light (UL1971 110cd)
Cat. No. xxxx-W = Strobe Light (UL1971 15/75cd)	Cat. No. xxxx-M = Sync Strobe Light (UL1971 15/75cd)
Cat. No. xxxx-D = Strobe Light (UL1971 75cd)	Cat. No. xxxx-R = Sync Strobe Light (UL1971 30/75cd)
Cat. No. xxxx-S = Strobe Light (UL1971 110cd)	Cat. No. xxxx-T = Sync Strobe Light (UL1971 60/75cd)
Cat. No. xxxx-A = Sync Strobe Light (UL1971 15cd)	Cat. No. xxxx-Y = Sync Strobe Light (UL1971 75cd)
Cat. No. xxxx-B = Sync Strobe Light (UL1971 15/75cd)	Cat. No. xxxx-Z = Sync Strobe Light (UL1971 110cd)
Cat. No. xxxx-C = Sync Strobe Light (UL1971 75cd)	

Compatible Accessory Devices

Order No.	Mfg Part Number	Description
Faraday		
R711-1	711-1	Polarized Auxiliary Relay
MEP-100	15050	Mini-Evac Control Unit
RSE-100	15070	Signal Expander Panel
15222A	15222A	Signal Expander Panel
MVP-600	15612	Voice Evacuation Unit
MVP-500	15060	Mini-Voice Control Unit
MVP-501	15061	Mini-Voice Control Unit

Notes:

1. The accessory devices listed above may be wired to activate from the notification appliance circuits.
2. For specific wiring and installation information, read the instructions provided with each device.

INSTALLATION INSTRUCTIONS AND WIRING FOR REMOTE LCD ANNUNCIATOR CAT. NO. RDC-1 P/N 12506

The 12506 Remote LCD Annunciator is an optional accessory for the 12100 or 12500 Fire Alarm System Control Unit. The 12506 provides a 80 character LCD display along with the system status LEDs. The button enable keyswitch allows system reset, trouble silence/acknowledge, alarm silence and menu access. The lamp test operation is also enabled by the keyswitch, but the function is limited to the annunciator. The annunciator mounts to a horizontally mounted 6-gang box, 2" deep minimum. The Faraday 12411 Surface Backbox may be used for surface mounting.

PARTS SUPPLIED

1	12506	Remote LCD Annunciator
4	940865	Mounting Screws
1	443269	Screwdriver
1	446983	Instruction Sheet
1	446984	Operating Instructions

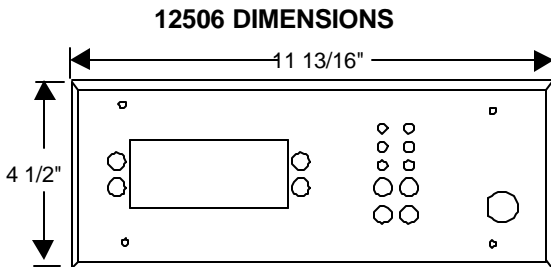

12506 WIRING

Power Limited and Supervised

Cable for power (+ & -) and Twisted pair Cable for data (X+ & X-) from panel or previous remote connects to

Cable for power (+ & -) and Twisted pair Cable for data (X+ & X-) to next remote or 120 ohm termination resistor (Faraday P/N 942664) on the last remote.

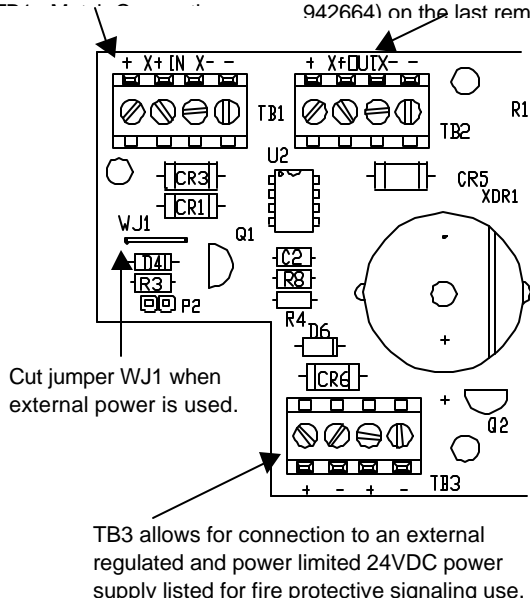

- Step 1.) Installation is to be done by qualified personnel who have thoroughly read and understood this instruction sheet.
- Step 2.) Disconnect all power into system, including batteries.
- Step 3.) Mount 6-gang backbox horizontally as required (see mounting below).
- Step 4.) Set dip switch for proper remote address (1- 16).
- Step 5.) Attach conduit and run wires as required.
- Step 6.) Connect IN wires from fire alarm system control unit or previous remote as required.
- Step 7.) Connect OUT wires to next remote or 120 ohm terminating resistor (Faraday P/N 942664), if last remote.
- Step 8.) Attach unit to backbox, using four P/N 940865 screws.
- Step 9.) Apply power to system.
- Step 10.) Check for proper operation of functions.

12411 DIMENSIONS

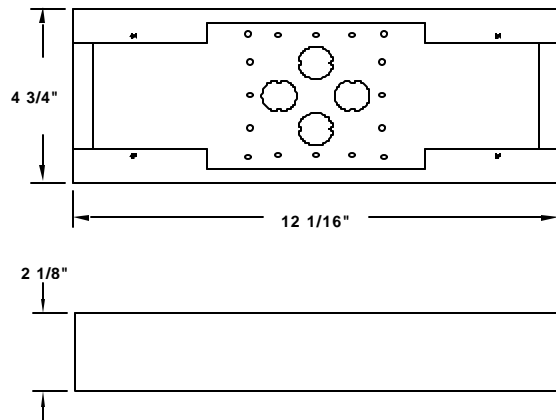

Notes:

- 1.) Units to be installed in accordance with all local codes.
- 2.) T-Tapping is not allowed! Communication wiring must be daisy chained from remote to remote.
- 3.) Terminal block will accept a maximum of 12 AWG wiring
- 4.) Use twisted pair cable with a characteristic impedance of approximately 120 ohms. 4000 feet maximum distance from panel to last remote.

The following table shows the dip switch settings for proper addressing of the 12506 remotes.

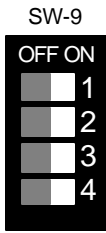

Address	Switch 1	Switch 2	Switch 3	Switch 4
1	On	On	On	On
2	Off	On	On	On
3	On	Off	On	On
4	Off	Off	On	On
5	On	On	Off	On
6	Off	On	Off	On
7	On	Off	Off	On
8	Off	Off	Off	On
9	On	On	On	Off
10	Off	On	On	Off
11	On	Off	On	Off
12	Off	Off	On	Off
13	On	On	Off	Off
14	Off	On	Off	Off
15	On	Off	Off	Off
16	Off	Off	Off	Off

INSTALLATION INSTRUCTIONS AND WIRING FOR SERIAL RELAY UNIT CAT. NO. SRU-1 P/N 12507 AND SERIAL RELAY EXTENDER CAT. NO. SRE-8 P/N 12508

The 12507 Serial Relay Unit is an optional accessory for the 12100 or 12500 Fire Alarm System Control Unit. The 12507 includes a processor board and a relay board. The processor board receives commands from the control unit for activating the relays and transmits supervision and control functions to the control unit. The processor board can control up to 3 relay boards. Each relay board provides 8 relays with form C contacts. The control unit can address up to 8 Serial Relay Units and/or Serial Annunciator Units. Auxiliary power supplies will be required to power units beyond the control unit capability.

12507 PARTS SUPPLIED

- 1 413320 Processor Board Assembly
- 1 413321 Relay Board Assembly
- 1 446653 34 pin Cable Assembly, 3 1/2"
- 1 447042 PCB Track, 14 1/2"
- 1 447080 10 pin Cable Assembly, 6"
- 1 443269 Screwdriver
- 3 18965 Keps Nut, #6-32
- 1 447073 Instruction Sheet

12508 PARTS SUPPLIED

- 1 413321 Relay Board Assembly
- 1 446652 34 pin Cable Assembly, 15"
- 1 446653 34 pin Cable Assembly, 3 1/2"
- 1 447042 PCB Track, 14 1/2"
- 3 18965 Keps Nut, #6-32
- 1 447073 Instruction Sheet

12507 DIMENSIONS

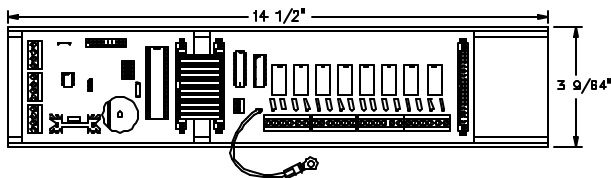

12508 DIMENSIONS

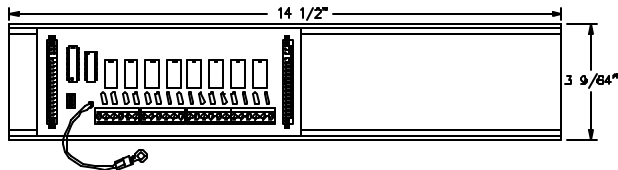

- Step 1.) Installation is to be done by qualified personnel who have thoroughly read and understood this instruction sheet.
- Step 2.) Disconnect all power into system, including batteries.
- Step 3.) Mount enclosure as required.
- Note: Enclosure must be UL Listed for Fire Protective Signaling Use (Faraday P/N 401403 Fire Alarm Accessory Enclosure).
- Step 4.) Attach conduit and run wires as required.
- Step 5.) Set processor board dip switch for proper remote address (1- 8).
- Step 6.) Set each relay board dip switch for proper relay set number (1- 8, 9-16, 17-24).

Note: Relays are numbered from left to right:

Relay Set	TB1		TB2		TB3		TB4	
(1-8)	1	2	3	4	5	6	7	8
(9-16)	9	10	11	12	13	14	15	16
(17-24)	17	18	19	20	21	22	23	24

- Step 7.) Set jumper P6 for desired buzzer operation.

J6 – BUZZER ACTIVATION

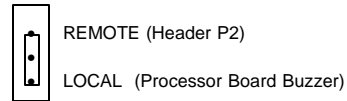

- Step 8.) Mount PCB Track(s) using #6-32 keps nuts (P/N 18965) and snap in PCB assemblies.
- Step 9. Plug in the cable assembly(s) to the PCB assemblies as required.
- Step 10. Connect ground wire(s) to chassis ground using #6-32 keps nut(s) (P/N 18965).
- Step 11.) Connect IN wires from fire alarm system control unit or previous remote as required.
- Step 12.) Connect OUT wires to next remote or 120 ohm terminating resistor (Faraday P/N 942664), if last remote.
- Step 13.) Connect relay contacts, as required.
- Step 14.) Apply power to system.
- Step 15.) Program control unit for required relay operation.
- Step 16.) Check for proper operation of functions.

12507/12508 WIRING

Power Limited, Supervised

Cable for power (+ & -) and Twisted pair Cable for data (X+ & X-) from panel or previous remote.

Cable for power (+ & -) and Twisted pair Cable for data (X+ & X-) to next remote or 120 ohm termination resistor (Faraday P/N 942664) on

TB3 allows for connection to an external regulated and power limited 24VDC power supply, listed for fire protective signaling use. Cut jumper WJ1 when external power is used.

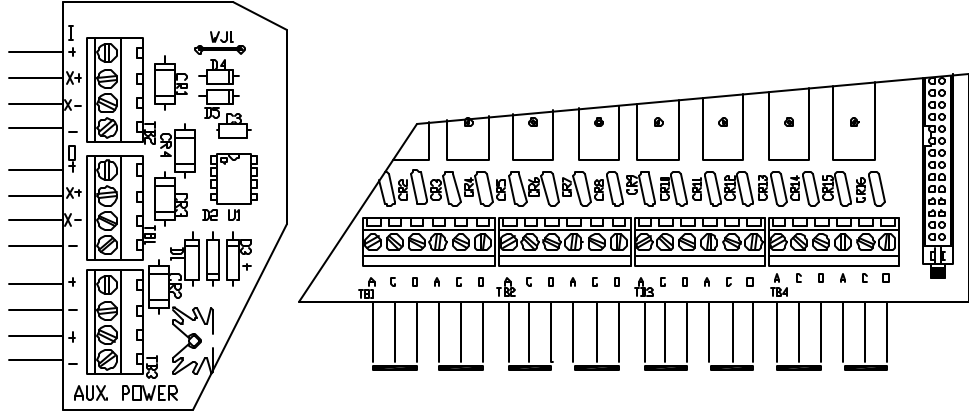

Relay Contacts
(Shown in normal standby condition)
1A@28VDC max., Resistive
For Power Limited Source, Unsupervised

Notes:

- 1.) Units to be installed in accordance with all local codes.
- 2.) T-Tapping is not allowed! Communication wiring must be daisy chained from unit to unit.
- 3.) Terminal block will accept a maximum of 12 AWG wiring
- 4.) Use twisted pair cable with a characteristic impedance of approximately 120 ohms. 4000 feet maximum distance from end to end.
- 5.) Power Limited wiring must be kept separate from non-power limited wiring, ¼ " minimum.
- 6.) The following table gives the currents necessary for power supply and battery calculations.

Model	Standby Current	Alarm Current
12507	0.010 A.	0.170 (All relays activated)
12508	0.000 A.	0.160 (All relays activated)

12507 ADDRESS SETTING

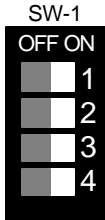

Address	Switch 1	Switch 2	Switch 3	Switch 4
1	On	On	On	Not Used
2	Off	On	On	Not Used
3	On	Off	On	Not Used
4	Off	Off	On	Not Used
5	On	On	Off	Not Used
6	Off	On	Off	Not Used
7	On	Off	Off	Not Used
8	Off	Off	Off	Not Used

PROCESSOR BOARD HEADER CONNECTIONS

Pin	P2 - Processor Board
1	24V Output
2	Not Used
3	Lamp Test Switch
4	Alarm Silence Switch
5	Trouble Acknowledge/Silence Switch
6	System Reset Switch
7	Remote Buzzer Output (open collector)
8	Alarm Silence Output (open collector)
9	Trouble Output (open collector)
10	Minus

**INSTALLATION INSTRUCTIONS AND WIRING FOR
SERIAL ANNUNCIATOR UNIT
CAT. NO. SAU-1 P/N 12509
AND
SERIAL ANNUNCIATOR EXTENDER
CAT. NO. SAE-16 P/N 12510**

The 12509 Annunciator Unit is an optional accessory for the 12100 or 12500 Fire Alarm System Control Unit. The 12509 includes a processor board and an annunciator driver board. The processor board receives commands from the control unit for activating the outputs and transmits supervision and control functions to the control unit. The processor board can control up to 4 annunciator driver boards. Each driver board provides 16 supervised outputs for LEDs or incandescent lamps. The control unit can address up to 8 Serial Relay Units and/or Serial Annunciator Units. Auxiliary power supplies will be required to power units beyond the control unit capability.

12509 PARTS SUPPLIED

1	413320	Processor Board Assembly
1	413322	Annunciator Driver Board Assembly
1	446653	34 pin Cable Assembly, 3 1/2"
1	447042	PCB Track, 14 1/2"
3	447080	10 pin Cable Assembly, 6"
2	18965	Keps Nut, #6-32
1	443269	Screwdriver
1	447074	Instruction Sheet

12510 PARTS SUPPLIED

1	413322	Annunciator Driver Board Assembly
1	446652	34 pin Cable Assembly, 15"
1	446653	34 pin Cable Assembly, 3 1/2"
1	447042	PCB Track, 14 1/2"
2	447080	10 pin Cable Assembly, 6"
2	18965	Keps Nut, #6-32
1	447074	Instruction Sheet

12509 DIMENSIONS

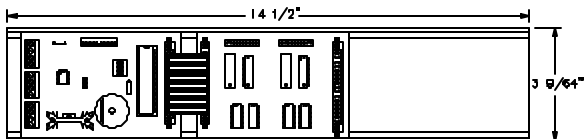

12510 DIMENSIONS

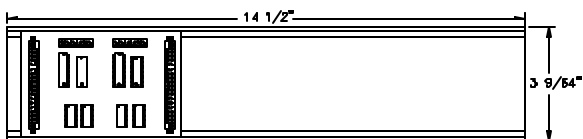

- Step 1.) Installation is to be done by qualified personnel who have thoroughly read and understood this instruction sheet.
- Step 2.) Disconnect all power into system, including batteries.
- Step 3.) Mount enclosure as required.
- Note: Enclosure must be UL Listed for Fire Protective Signaling Use (Faraday P/N 401403 Fire Alarm Accessory Enclosure).
- Step 4.) Attach conduit and run wires as required.
- Step 5.) Set processor board dip switch for proper remote address (1- 8).
- Step 6.) Set jumper P6 for desired buzzer operation.

J6 – BUZZER ACTIVATION

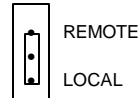

- Step 7.) Mount PCB Track(s) using #6-32 keps nuts (P/N 18965) and snap in PCB assemblies.
- Step 8.) Plug in the cable assembly(s) to the PCB assemblies as required.
- Step 9.) Connect IN wires from fire alarm system control unit or previous remote as required.
- Step 10.) Connect OUT wires to next remote or 120 ohm terminating resistor (Faraday P/N 942664), if last remote.
- Step 11.) Connect LED's or lamps, as required.
- Step 12.) Apply power to system.
- Step 13.) Program control unit for required annunciator operation.
- Step 14.) Check for proper operation of functions.

12509/12510 WIRING

Annunciator Driver Outputs
 Activated Voltage Range: 16-28VDC
 Activated Current (max.): 0.070A
 Power Limited, Supervised for opens
 Unused outputs must have a 220K ohm dummy resistor

Power Limited, Supervised

Cable for power (+ & -) and Twisted pair Cable for data (X+ & X-) from panel or previous remote.

Cable for power (+ & -) and Twisted pair Cable for data (X+ & X-) to next remote or 120 ohm termination resistor (Faraday P/N 942664) on the last remote.

TB3 allows for connection to an external regulated and power limited 24VDC power supply, listed for fire protective signaling use.
 Cut WJ1 when external power is used.

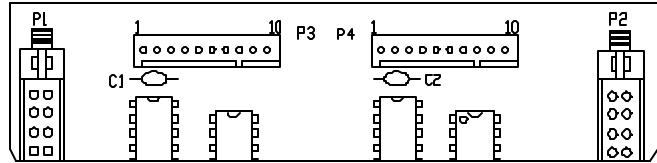
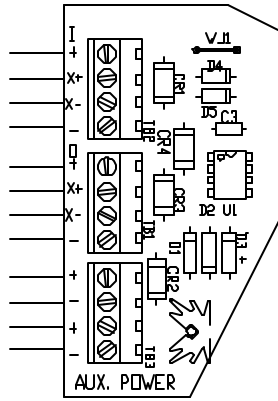

Notes:

- 1.) Units to be installed in accordance with all local codes.
- 2.) T-Tapping is not allowed! Communication wiring must be daisy chained from unit to unit.
- 3.) Terminal block will accept a maximum of 12 AWG wiring
- 4.) Use twisted pair cable with a characteristic impedance of approximately 120 ohms. 4000 feet maximum distance from end to end.
- 5.) Power Limited wiring must be kept separate from non-power limited wiring, 1/4" minimum.
- 6.) The following table gives the currents necessary for power supply and battery calculations.

Model	Standby Current	Activated Current
12509	0.015 A.	0.040 + Lamp or LED current
12510	0.005 A.	0.000 + Lamp or LED current

12509 ADDRESS SETTING

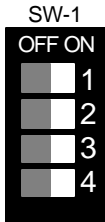

Address	Switch 1	Switch 2	Switch 3	Switch 4
1	On	On	On	Not Used
2	Off	On	On	Not Used
3	On	Off	On	Not Used
4	Off	Off	On	Not Used
5	On	On	Off	Not Used
6	Off	On	Off	Not Used
7	On	Off	Off	Not Used
8	Off	Off	Off	Not Used

12509/12510 HEADER CONNECTIONS

Pin	P2 - 12509 Processor Board	P3 - 12509 or 12510 Driver Board	P4 - 12509 or 12510 Driver Board
1	24V Output	24V Output	24V Output
2	Not Used	Indicator #1	Indicator #9
3	Lamp Test Switch	Indicator #2	Indicator #10
4	Alarm Silence Switch	Indicator #3	Indicator #11
5	Trouble Acknowledge/Silence Switch	Indicator #4	Indicator #12
6	System Reset Switch	Indicator #5	Indicator #13
7	Remote Buzzer Output (open collector)	Indicator #6	Indicator #14
8	Alarm Silence Output (open collector)	Indicator #7	Indicator #15
9	Trouble Output (open collector)	Indicator #8	Indicator #16
10	Minus	Not Used	Not Used

INSTALLATION INSTRUCTIONS AND WIRING FOR FIRE ALARM ACCESSORY ENCLOSURE CAT. NO. FAE-21 P/N 401403 AND SEMI-FLUSH TRIM CAT. NO. SFT-21 P/N 401404

The 401403 Fire Alarm Accessory Enclosure is an optional accessory for the 12100 or 12500 Fire Alarm System Control Unit. The 401403 provides an enclosure for 12507 and 12508 Serial Relay Units and 12509 and 12510 Serial Annunciator Units. The 401403 enclosure provides mounting of up to two 12507 units and two 12508 extenders or two 12509 units and five 12510 extenders.

401403 PARTS SUPPLIED

1	447160	Back Box
1	413754	Door Assembly
1	447138	Instruction Sheet

401404 PARTS SUPPLIED

1	447166	Semi-Flush Trim
4	940454	Wood Screw, #10x3/4"

Step 1.) Installation is to be done by qualified personnel who have thoroughly read and understood this instruction sheet.

Step 2.) Mount enclosure as required.

Step 3.) Attach conduit and run wires as required.

Step 4.) Mount PCB Tracks as required.

Note: See the installation instructions provided with relay or annunciator units for installation and wiring.

401403 SURFACE MOUNTING

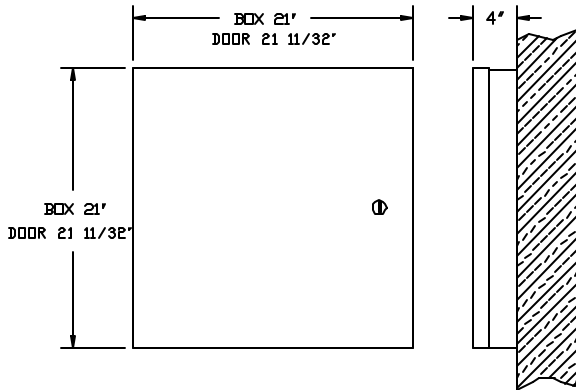

KNOCK-OUT LOCATION

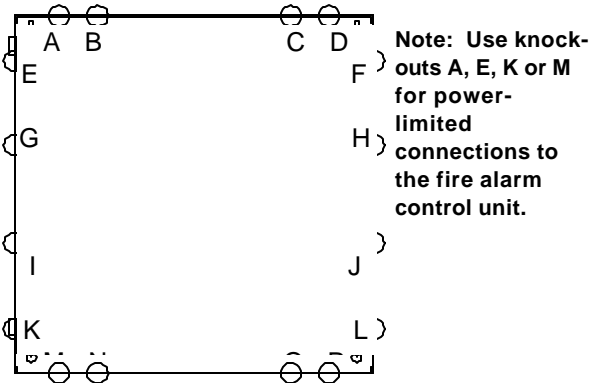

401403 SEMI-FLUSH MOUNTING WITH 401404 SEMI-FLUSH TRIM

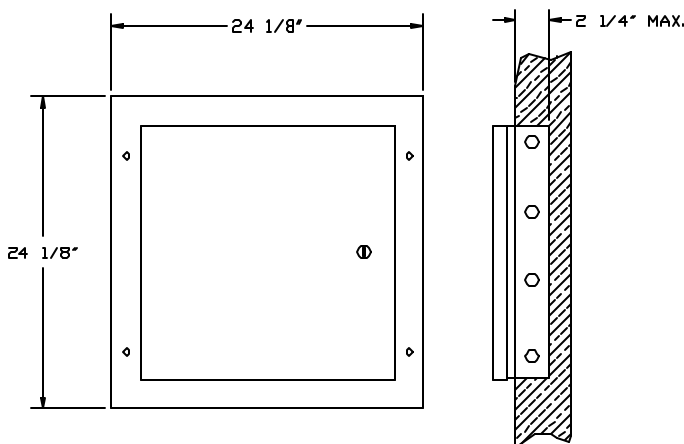

401403 DIMENSIONS

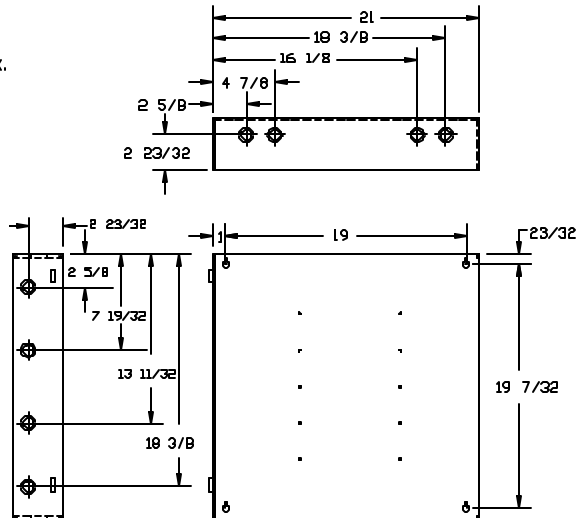

SAMPLE LAYOUT FOR RELAY UNITS

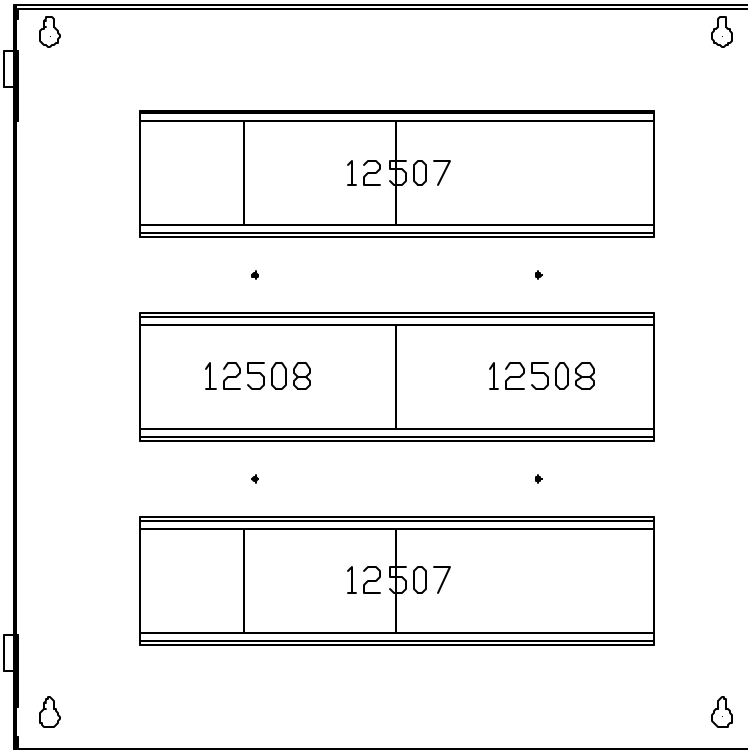

SAMPLE LAYOUT FOR ANNUNCIATOR UNITS

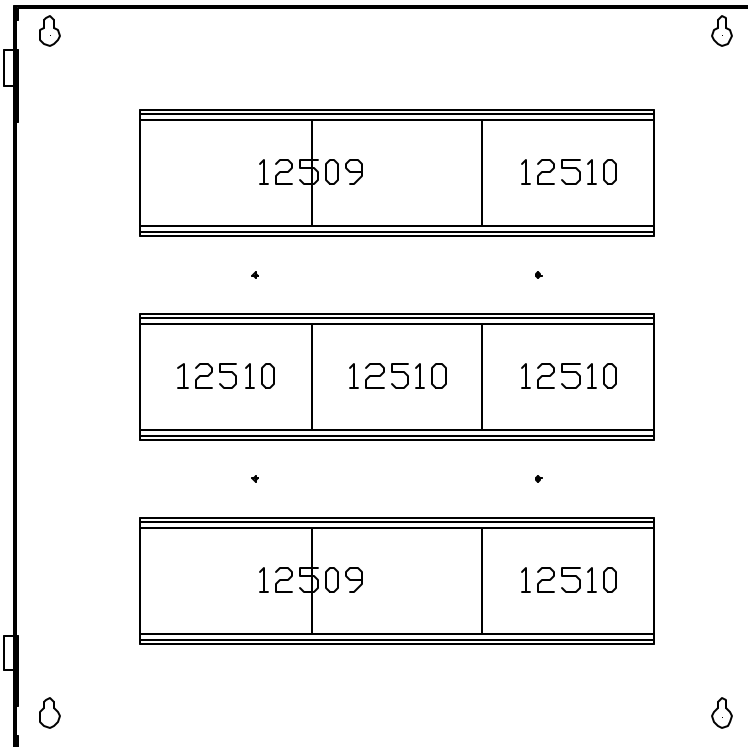

XII. APPENDIX-E: GLOSSARY

Alarm Signal. A signal indicating an emergency requiring immediate action, such as an alarm for fire from a manual station, a waterflow alarm, or a automatic smoke detector.

Alarm Silence Inhibit. An option that prevents a human operator from silencing the notification appliances for a preset period of time.

Alarm System. A combination of compatible initiating devices, control units, and notification appliances designed and installed to produce an alarm signal in the event of a fire.

Alarm Verification. A preset option that causes the control unit to verify alarms originated by smoke detectors before indicating an alarm.

Annunciator. A remotely located, electrically powered display, separate from the control unit, containing LEDs or lamps to indicate the states of the fire alarm system.

Audible Signal. An audible signal is a sound made by one or more audible notification appliances, such as bells or horns, in response to the operation of an initiating device.

Authority Having Jurisdiction (AHJ). The organization, office, or individual responsible for approving equipment, installation or procedure.

Auto-Silence. The capability of a control to automatically silence the notification appliances after a preset period of time.

Auxiliary Relays. Control relays that energize only during alarm conditions that are used to either apply power to or remove power from other equipment during an alarm condition.

Class A Circuit. An initiating device or notification appliance circuit within which all components remain fully functional, even though a single open or ground exists in the circuit.

Class B Circuit. An initiating device or notification appliance circuit within which some or all components may be disabled with a single open or ground exists in the circuit.

Detector - Smoke, Ionization Type. A detector employing the principle of smoke's effect on an electrical current flowing in an ionized air chamber.

Detector - Smoke, Photoelectric Type. A detector employing the photoelectric principle of reflection or obstruction of light by smoke.

End Of Line (EOL). A device used to terminate a supervised circuit.

General Alarm. A term usually applied to the simultaneous operation of all the notification appliances on a system.

Ground Fault. A trouble condition in which a low resistance has been detected between the system wiring and conduit ground.

Initiating Device. A manually or automatically operated device such as a manual pull station, smoke detector, heat detector, waterflow switch or tamper switch.

Initiating Device Circuit (IDC). A circuit to which initiating devices are connected.

Labeled. Equipment or materials to which have been attached a label, symbol, or other identifying mark of an organization acceptable to the authority having jurisdiction and concerned with product evaluation, that maintains periodic inspection of the production of such labeled equipment or materials. And by whose labeling the manufacturer indicates compliance with appropriate standards or performance in a specified manner.

Listed. Equipment or materials included in a list published by an organization acceptable to the authority having jurisdiction and concerned with product evaluation, that maintains periodic inspection of production of listed equipment or materials. And whose listing states either that the equipment or material meets appropriate standards or has been tested and found suitable for use in a specified manner.

NEC. National Electrical Code also published as NFPA standard 70.

Notification Appliance. An electrically operated appliance used to indicate the system status such as a bell, horn, strobe light or speaker.

Notification Appliance Circuit (NAC). A circuit to which notification appliances are connected.

Power Supply. That portion of the fire alarm control unit, which provides the power needed to operate all control unit modules, as well as that, needed to operate all electrically powered initiating devices and all notification appliances.

Quick Test. A term pertaining to the test mode of the system, that automatically resets after a service technician tests initiating devices.

Supervisory Alarm. A signal indicating the operation of a supervisory device.

Supervisory Device. A device that monitors the condition of a sprinkler system such as a gate-valve switch, water-level switch, low pressure switch, low temperature switch or fire pump monitor.

Trouble Signal. An audible signal indicating trouble of any nature, such as a circuit break or ground, occurring in the device or wiring associated with a fire alarm signal.

Waterflow Switch. An assembly approved for service and so constructed and installed that any flow of water from a sprinkler system equal to or greater than that from a single automatic sprinkler head will result in activation of this switch and subsequent indication of an alarm condition.

Zone. A designated area of a building. Commonly, zone, is interchanged with initiating device circuit.