

MPC-1000 Addressable Fire Alarm Control Panel

Features

- One analog addressable SLC (198 pts.)
- Four NACs, style "Y" (Class A)
- Three (3) amp power supply
- 80 character, backlit LCD with custom labeling
- LEDs for panel status indication
- Connection for 16 remote 80 character display/control LCD annunciators, backlit on activation
- Optional DACT connection
- Fully field programmable via PC, removable keypad or automatic programming
- 500 event history log in nonvolatile memory
- Dynamic "quick test" functions
- Day/Night sensitivity mode
- NFPA 72 sensitivity testing
- Manual alarm silence with 0, 1, 3, or 6 minute inhibit
- Auto-silence selectable for each NAC (10, 20, or 30 minute, or none)
- "Quick Test" by device or the entire panel
- Silent or audible Quick Test
- 59 Software zones, 255 notification and 255 relay software circuits
- Two password levels
- UL Listed, standard 864, CSFM listed and MEA approved
- Made in U.S.A, ISO 9001 quality crafted



MPC-1000

Description

The **MPC-1000** is an advanced modular fire alarm panel. It features analog/addressable detection, programming, and memory capability. Its base configuration includes one analog/addressable loop, with four conventional notification appliance output circuits.

Operating controls and indicators are mounted behind a locked cabinet door and an 80-character LCD display provides specific indications for addressable devices, while LEDs indicate general panel status.

Hardware Configuration

The main termination board mounts in the rear of the panel. The main power supply is physically contiguous with the main termination board. The MPC-1000 main termination board provides the interface for external analog system connections, the analog loop interface PCB, four signaling circuits, remote signaling circuits and indicating interfaces, and the electronics of the main system power supply.

The front main logic PCB mounts in the back box, allowing it to carry the controls and displays which are accessible from the front locked panel door. Displays for any number of zones are handled through this board.

... continued

All normal operation is controlled from the front of the panel via push-button switches. Displays are provided by an 80-character, alphanumeric, backlit LCD display and by discrete LED indicators for major panel functions.

The 80-character LCD display is used to display event data, including alarms and troubles, identification of zone or device, and presentation of history. The display is controlled by a set of four push-button switches commanding the control processor. A back light is included in the display to assure visibility in low light, but to conserve power, it is only activated during a reported event or operation of a display control switch.

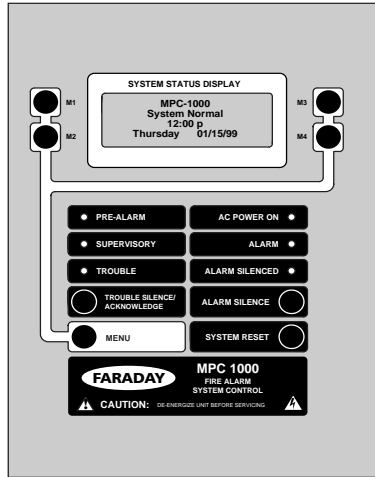

Minimum Control Unit Configuration

- A. **Addressable Input/Output Circuits** – The addressable main termination board has addressable loop interface circuitry supporting one addressable device communication loop.
- B. **Notification Appliance Circuits** – The base panel has four independent NACs. Each circuit can be selected to give continuous output, one of eight sounding patterns, or zone coding. NACs are style Z or Y capable, without additional modules.
- C. **Dry Contacts** – Three form "C" dry relay contacts are provided. These contacts are dedicated to alarm, trouble and supervisory indications.
- D. **Digital Dialer Output** – The main analog/termination board provides a standard DACT interface, providing more extensive data to a remote receiving station.
- E. **Remote Annunciation** – The MPC-1000 panel will drive up to 16 annunciators and 8 remote processors on an RS-485 communication line.
- F. **Power Supply** – A 3.0A, 24V nominal power supply provides all operating power to the panel for both standby and alarm conditions. 2.5 Amps are available for the NAC circuit.

Optional LCD Annunciator (RDC-1) –

General Specifications

Environmental
 Operating Temperature- 32-120°F (0-49°C)
 Relative Humidity-Extreme: 85% @ 86°F

Power Consumption
 Alarm: .025 Amp
 Standby: .020 Amp

Transmission Format
 Multiplexed, supervised, power limited

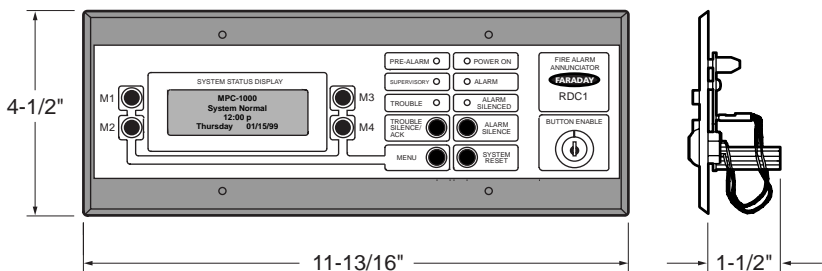

Display
 80 character, alphanumeric, backlit

Wiring
 25 ohms/line (4000 ft. max.)
 twisted pair for data

Mounting
 6 gang box (supplied by others)

Shipping Weight
 2 lbs. approx.

Auxiliary Devices

- A. **Remote LCD Annunciator (RDC-1)** – The remote LCD annunciator consists of a backlit 80 character, alphanumeric display, 4 menu buttons, 4 dedicated buttons for operator interaction, 6 LED indicators, and a security key switch.
- B. **Serial Annunciator (SAU-1)** – Consists of remote processor and annunciator driver board capable of providing 16 supervised outputs for LEDs or incandescent lamps. Expansion to drive 512 LEDs or lamps is via additional processor boards and annunciator drive boards.
- C. **Serial Relay Unit (SRU-1)** – Consists of remote processor and relay board which provides 8 relays with form "C" dry contacts rated at 1 amp. Expansion to 192 relays is via additional remote processor boards and relay boards.
- D. **Serial Annunciator Extender** – Each remote processor board receives commands from the control unit and is capable of controlling three relay boards and four annunciator boards. Maximum of 8 remote processor boards in one system. Auxiliary power supplies will be required to power units beyond the control unit capability.

Wiring, Main Termination Board

Note: All wiring must be in accordance with local codes and National Electric Code. Use only FPL, FPLR and/or FPLP as described in Article 760 of N.E.C.

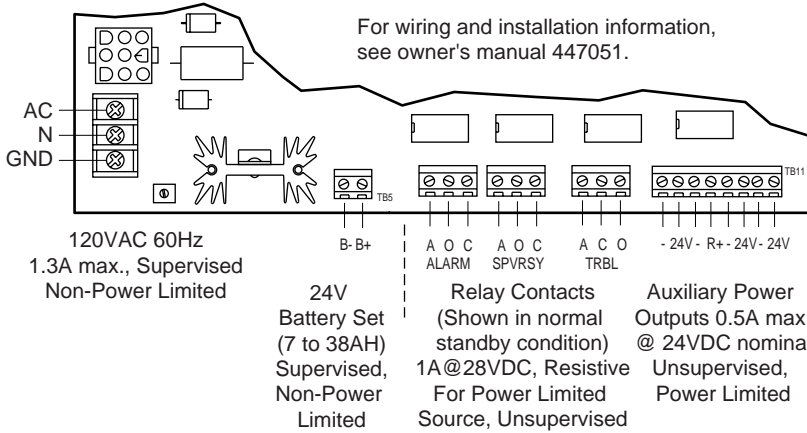

Addressable Device Circuit
Style 4, 6 or 7 Operation
(set jumper P1 for proper style)
24VDC nominal
Wire Resistance-20 ohms/line
Supervised, Power Limited
See Owner's Manual for Compatible Devices

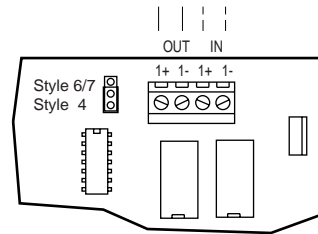

Keep All Non-Power Limited Wiring Separate from Power Limited Wiring

Serial Interface Circuit
24VDC nominal, 0.4A max.
Wire Resistance - 25 ohms/line (4000 ft. max.)
Wire Type - Twisted Pair for Data
Supervised Power Limited

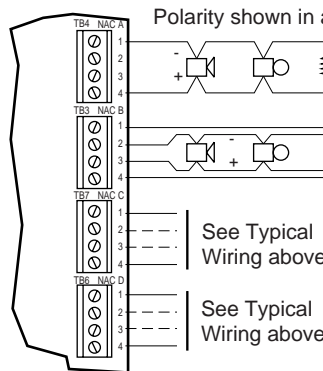
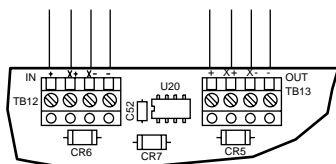

NAC
Style Y, Class B
Supervised, Power Limited

NAC
Style Z, Class A
Supervised, Power Limited

NAC Ratings:
Alarm Voltage: 24VDC nominal
Max. Alarm Current: 1.5A
Max. Ripple: 16VAC
Max. Wire Voltage Drop: 1.0VDC
Max. Standby Current: 1.0mA

NOTE: The maximum current for all NACs is 2.5A

General Specifications

Environmental

Operating temperature -
32-120°F (0-49°C)
Relative Humidity -
85% @ 86°F

Primary Supply

Primary input voltage -
120 Vac (50/60 Hz.), 240 Vac (50/60 Hz.)
Maximum primary input current -
1.3 amp @ 120 Vac

Secondary and Trouble Power Supply

24 volt lead-acid battery with 7 AH-38 AH capacity

Auxiliary Power Outputs

Current - 0.5 amp resettable/non-resettable power outputs

Status System Relays

3 relays rated @ 1 amp, 28 Vdc resistive

NAC Circuits

Panel power supply per ckt., 0.9 amp ea.
Rating per NAC circuit, 1.5A ea., 2.5 max.

Battery

Base cabinet will accommodate a 7 AH battery set. Larger batteries will require separate enclosure

Dimensions

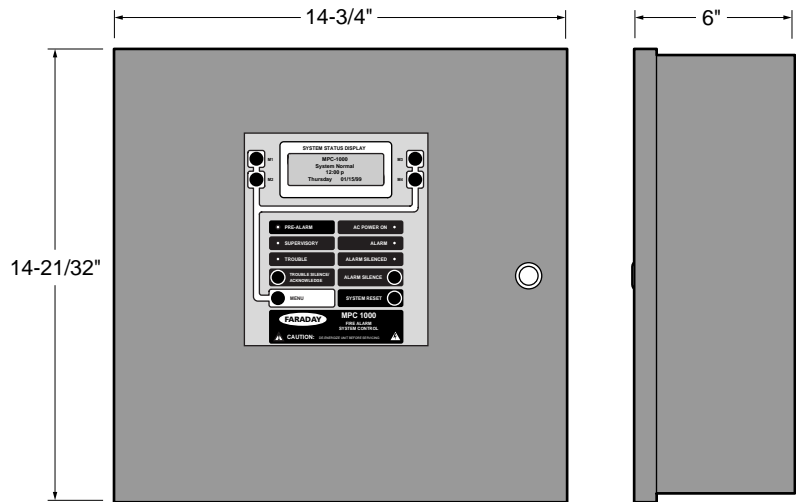

Ordering Information

Model No.	Order No	Description
-----------	----------	-------------

MPC-1000 Control Panel – (1) analog/addressable loop and 4 NACs, style "Y" (class B)

MPC-1000	12100-0-(*)-120	Base unit with surface cabinet, 120 Vac, 60 Hz.
MPC-1000	12110-0-(*)-120	Base unit with built-in DACT

Options for MPC-1000

RDC-1	12506-0-14	Remote 80 character LCD annunciator
SRU-1	12507	Serial relay unit
SRE-8	12508	Serial relay extender
SAU-1	12509	Serial annunciator unit
SAE-16	12510	Serial annunciator extender
IM232	12103	RS-232 interface module (reqd. for printer or computer conn.)
DC1K	12105	Communicator (DACT)
15216	15216	Semi-Flush trim
CIS-3	12106	Upload/Download programming software (includes software, cable & board)

* Available colors – (14) red, (21) off-white



805 S. Maumee Street
Tecumseh, MI 49286, U.S.A.
Phone: (800) 465-7115
Fax: (800) 552-3557
Web: www.faradayllc.com

WARNING - The information contained in this document is intended only as a summary and is subject to change without notice. The devices described in this document have specific instruction sheets which cover various technical, limitation and liability information. Copies of these instruction sheets and the General Product Warning and Limitations Document, which also contains important information, are provided with the product and are available from the Manufacturer. Information contained in these documents should be consulted before specifying or using the product. For further information or assistance concerning particular problems contact the Manufacturer.